



ST. TAMMANY PARISH

PATRICIA P. BRISTER
PARISH PRESIDENT

July 19, 2018

Please find the following addendum to the below mentioned BID.

Addendum No.: 4
Bid#: 622-10-18-31-2
Project Name: Colonial Court Lift Station Upgrade
Bid Due Date: July 24, 2018

GENERAL INFORMATION:

1. Please **REPLACE** Section 33 32 00 – Sewage Pump Station in Section 10, Project Specifications with Section 33 32 00 – Sewage Pump Station – Revised (attached). A revision has been made to Paragraph 1.2.C. The Wastecorp Pump option has been deleted.
2. Please **REPLACE** Section 33 39 16 – Lining Systems for Wastewater Structures in Section 10, Project Specifications with Section 33 39 16 – Lining Systems for Wastewater Structures – Revised (attached). Corrections have been made to Paragraphs 1.4 – Quality Insurance, 2.1.A – Liner Products and Materials, and 2.3.B – Geopolymer Lining System.

ATTACHMENTS:

1. Section 10 Project Specifications, Section 33 32 00 – Sewage Pump Station – Revised.pdf
2. Section 10 Project Specifications, Section 33 39 16 – Lining Systems for Wastewater Structures - Revised.pdf

<< End of Addendum # 4 >>

SECTION 33 32 00 - SEWAGE PUMP STATION - Revised

PART 1 GENERAL

1.1 DESCRIPTION

- A. The Work of this section includes, but is not limited to, sewage pump station with wet well, self-priming centrifugal solids handling pumps, piping, valves, and all appurtenances for a complete installation.
- B. Related Work specified elsewhere:
 - 1. Section 03 30 00 - Cast-In-Place Concrete
 - 2. Section 03 60 00 - Grout
 - 3. Section 09 90 00 - Painting
 - 4. Section 31 20 00 - Earthwork
 - 5. Section 31 23 17 - Trenching, Backfilling & Compacting
 - 6. Section 33 31 13 - Sanitary Sewer Pipe

1.2 QUALITY ASSURANCE (Revised – Addenda 3 & 4)

- A. Self-Priming Centrifugal Pump Design Criteria (each pump):
 - 1. Capacity: 706 GPM @ 142' TDH Design Point
<500 gpm @ >156' TDH Shutoff
>900 gpm @ <134' TDH Runout
 - 2. Motor: 60 HP minimum
Non-overloading @ entire range
480 V, 3-phase, 60 Hz
 - 3. Pump Discharge: 4" diameter minimum
- B. All electrical equipment to be installed must meet the requirements of Article 500, "Hazardous Locations", of the National Electric Code (NEC) of the National Fire Protection Association (NFPA), or "NEC-500". All electrical equipment installed inside the wet well or within three feet (3') of the wet well vent must be UL approved to meet the requirements for use in Class 1, Group D, Division 1 locations as defined in NEC-500. All electrical equipment installed within three feet (3') of the wet well hatch or within five feet (5') of the wet well vent must be UL approved to meet the requirements for use in Class 1, Group D, Division 2 locations as defined in NEC-500.
- C. Both pumps shall be of the same manufacturer and model which shall be one of the following:
 - 1. Gorman-Rupp model V4A-B-1;
 - a. impeller diameter: 9.75"
 - b. pump discharge: 4"
 - c. pump speed: 2385 RPM
 - d. speed ratio = 1:1.36
 - 2. Crown Pumps model PO6LC-14X;
 - a. impeller diameter: 14.00"
 - b. pump discharge: 6"
 - c. pump speed: 1600 RPM
 - d. speed ratio = 1.09:1
 - 3. Approved Equal.

1.3 SUBMITTALS

- A. Equipment Certification: At the time of submitting shop drawings, submit the equipment manufacturer's warranty and certification attesting that the manufacturer has examined the Contract Drawings and Specifications and that the equipment provided will meet the performance criteria and conforms to specification requirements.

- B. Shop Drawings and Product Data:
 - 1. Submit the required number of copies of certified detailed installation shop drawings for basin assembly, pumps, piping, controls and accessories including wiring schematics.
 - 2. Submit manufacturer's latest published literature for all materials specified under this Section.
 - 3. Before shipment, submit certified pump curves showing head/capacity relationships after pump assemblies have been fabricated and performance tested at the factory. Submit certified results of all start-up and performance tests.
 - 4. Submit calculations for the wet well and valve vault which verify that each structure's weight is sufficient to counteract hydrostatic uplift using a 1.5 safety factor.
- C. Maintenance Data and Operating Instructions: At time of delivery, submit the required number of copies of Operation and Maintenance Manuals for the pump station furnished including a detailed description of the operation of each principal component, procedures for operation, instructions for overhaul and maintenance, lubrication schedule, safety precautions, test procedures, and parts lists.
- D. Maintenance Material (Spare Parts):
 - 1. At time of delivery, provide one complete set of manufacturer's recommended spare parts for each pump and motor assembly, including pump mechanical seals, bearings, bushings and gaskets.
 - 2. Package each part individually or in sets in moisture-proof containers or wrappings, clearly labeled with part name and manufacturer's part/stock number.
 - 3. Provide any special tools required for equipment maintenance.

1.4 FIELD SERVICES

- A. Provide the services of a manufacturer's representative experienced in the installation and operation of the pumping station supplied under this specification for not less than two 8-hour workdays on-site for installation inspection, start-up, and instructing Owner's operating personnel.
- B. Provide for the above services to be performed during two separate visits to the project site.

PART 2 PRODUCTS

2.1 SELF-PRIMING CENTRIFUGAL PUMPS (Revised – Addendum No. 3)

- A. Pump shall be horizontal, belt driven self-priming centrifugal type, designed specifically for handling raw unscreened domestic sanitary sewage or industrial waste.
- B. Materials and Construction Features
 - 1. Pump casing shall be cast iron Class 30 with integral volute scroll. Casing shall incorporate following features:
 - a. Mounting feet sized to prevent tipping or binding when pump is completely disassembled for maintenance.
 - b. Fill port cover plate, 3 1/2" diameter, shall be opened after loosening a positive lock clamp bar assembly. In consideration for safety, cap screw threads must provide slow release of pressure, and the clamp bar shall be retained by detente lugs. A non-metallic gasket shall prevent adhesion of the fill port cover to the casing while assuring a reliable seal.
 - c. Casing drain plug shall be at least 1 1/4" NPT to insure complete and rapid draining.
 - d. Liquid volume and recirculation port design shall be consistent with performance criteria listed under PART 1 - GENERAL of this section.
 - 2. Cover plate shall be cast iron Class 30. Design must incorporate the following maintenance features:
 - a. Retained by acorn nuts for complete access to pump interior. Cover plate removal must provide ample clearance for removal of stoppages, and allow service to the impeller, seal, wear plate or check valve without removing suction or discharge piping.

- b. A replaceable wear plate secured to the cover plate by weld studs and nuts shall be AISI 1015 HRS. Wear plate shall be self-cleaning design ensuring that debris is cleared away and does not collect on the impeller vanes.
 - c. Pressure relief valve shall be supplied in the cover plate. Relief valve shall open at 75-200 PSI.
 - d. Two O-rings of nitrile butadiene rubber material shall seal cover plate to pump casing.
 - e. Pusher bolt capability to assist in removal of cover plate. Pusher bolt threaded holes shall be sized to accept same retaining cap screws as used in rotating assembly.
 - f. Easy-grip handle shall be mounted to face of cover plate.
3. Rotating assembly, which includes impeller, shaft, mechanical shaft seal, lip seals, bearings, seal plate and bearing housing, must be removable as a single unit without disturbing the pump casing or piping. Design shall incorporate the following features:
- a. Seal plate and bearing housing shall be cast iron Class 30. Anti-rotation ribs shall be cast into the seal plate to reduce internal wear and maximize component life. Separate oil filled cavities, vented to atmosphere, shall be provided for shaft seal and bearings. Cavities must be cooled by the liquid pumped. Three lip seals will prevent leakage of oil.
 - 1) The bearing cavity shall have an oil level sight gauge and fill plug check valve. The clear sight gauge shall provide easy monitoring of the bearing cavity oil level and condition of oil without removal of the fill plug check valve. The check valve shall vent the cavity but prevent introduction of moist air to the bearings.
 - 2) The seal cavity shall have an oil level sight gauge and fill/vent plug. The clear sight gauge shall provide easy monitoring of the seal cavity oil level and condition of oil without removal of the fill/vent plug.
 - 3) Double lip seal shall provide an atmospheric path providing positive protection of bearings, with capability for external drainage monitoring.
 - b. Impeller shall be ductile iron, two vane, semi-open, non-clog, with integral pump out vanes on the back shroud. Impeller shall be statically or dynamically balanced. Impeller shall thread onto the pump shaft and be secured with a lock screw and conical washer.
 - c. Shaft shall be AISI 4140 alloy steel unless otherwise specified by the engineer, in which case AISI 17-4 pH stainless steel shall be supplied.
 - d. Bearings shall be anti-friction ball type of proper size and design to withstand all radial and thrust loads expected during normal operation. Bearings shall be oil lubricated from a dedicated reservoir. Pump designs which use the same oil to lubricate the bearings and shaft seal shall not be acceptable.
 - e. Shaft seal shall be oil lubricated mechanical type. The stationary and rotating seal faces shall be silicon carbide alloy. Each mating surface shall be lapped to within three light bands flatness (35 millionths of an inch), as measured by an optical flat under monochromatic light. The stationary seal seat shall be double floating by virtue of a dual O-ring design. An external O-ring secures the stationary seat to the seal plate, and an internal O-ring holds the faces in alignment during periods of mechanical or hydraulic shock (loads which cause shaft deflection, vibration, and axial/radial movement). Elastomers shall be Viton or an approved equal; cage and spring to be stainless steel. Seal shall be oil lubricated from a dedicated reservoir. The same oil shall not lubricate both shaft seal and shaft bearings. Seal shall be warranted in accordance with requirements listed under PART 1 - GENERAL of this section.
 - f. Pusher bolt capability to assist in removal of rotating assembly. Pusher bolt threaded holes shall be sized to accept same cap screws as used for retaining rotating assembly.
4. Adjustment of the impeller face clearance (distance between impeller and wear plate) shall be accomplished by external means.
- a. Clearances shall be maintained by a four point external shimless cover plate adjustment system, utilizing a four collar and four adjusting screw design allowing for incremental adjustment of clearances by hand as required. Each of the four points shall be lockable to prevent inadvertent clearance increases or decreases due to equipment vibration or accidental operator contact. The four point system also allows for equal clearance gaps at all points between the impeller and wear plate. Requirement of realignment of belts, couplings,

etc., shall not be acceptable. Cover plate shall be capable of being removed without disturbing clearance settings. Clearance adjustment systems that utilize less than four points will not be considered.

- b. There shall be provisions for additional clearance adjustment in the event that adjustment tolerances have been depleted from the cover plate side of the pump. The removal of stainless steel shims from the rotating assembly side of the pump shall allow for further adjustment as described above.
 - c. Clearance adjustment which requires movement of the shaft only, thereby adversely affecting seal working length or impeller back clearance, shall not be acceptable.
5. An externally removable suction check valve shall be molded Neoprene with integral steel and nylon reinforcement. A blow-out center shall protect pump casing from hydraulic shock or excessive pressure. Removal or installation of the check valve must be accomplished from the top of pump without disturbing the suction piping or completely draining the casing. Sole function of check valve shall be to save energy by eliminating need to reprime after each pumping cycle. Pumps requiring a suction check valve to assist reprime will not be acceptable.
 6. Pump shall include flange kit consisting of two ASA spool flanges that shall be one piece cast iron class 30 suitable for attachment to suction and discharge ports. Each spool shall have one 1-1/4" NPT and one 1/4" NPT tapped hole with pipe plugs for mounting gauges or other equipment.
 7. Pump manufacturer shall provide belt drive required to meet the design criteria.
- C. Serviceability
1. The pump manufacturer shall demonstrate to the engineer's satisfaction that consideration has been given to reducing maintenance costs by incorporating the following features.
 2. No special tools shall be required for replacement of any components within the pump.
- D. Drive Transmission (if required)
1. Power to pumps transmitted V-belt drive assemblies. The sheave/belt combination shall provide the speed ratio needed to achieve the specified pump operating conditions.
 2. Each drive assembly shall utilize at least two V-belts providing minimum a combined safety factor of 1.5. Computation of safety factors shall be based on performance data published by the drive manufacturer.
 3. Precise alignment tolerances of the drive assemblies shall be achieved by means of a belt/sheave alignment system resulting in the reduction of vibration, accelerated wear, and premature failure.
 4. The pump supplier shall submit power transmission calculations which document the following:
 - a. Ratio of pump/motor speed.
 - b. Pitch diameter of driver and driven sheaves.
 - c. Number of belts required per drive.
 - d. Theoretical horsepower transmitted per belt, based on vendor's data.
 - e. Center distance between pump and motor shafts.
 - f. Service factor applied to established design horsepower.
 - g. Safety factor ratio of power transmitted/brake horsepower required.
 5. Pump drives to be enclosed on all sides by a guard.
 - a. Guards must be completely removal without interference from any unit component and shall be securely fastened and braced to the unit base.
- E. Motors
1. Pump motors shall be 60 HP, 3 phase, 60 hertz, 460 VAC, horizontal OTEFC 1800 RPM, NEMA design B with cast iron frame with copper windings, induction type, with class F insulation and 1.15 SF for normal starting torque and low starting current characteristics, suitable for continuous service. The motors shall not overload at the design condition or at any head in the operating range as specified.

2.2 WET WELL

- A. Cast-In-Place concrete construction in accordance with Section 03 30 00 of these Specifications.

2.3 WET WELL ACCESS HATCHES

- A. Aluminum, flush, channel frame type. Valve vault hatch shall be single leaf. Wet well hatch shall be single or double leaf. Access hatch shall open so as not to interfere with pump lift out.
- B. 1/4" extruded aluminum channel frame with anchoring flange. 1-1/2" channel drain.
- C. Minimum 1/4" thick diamond checkered aluminum plate covers, designed for minimum 300 lbs/sq.ft. loading. Heavy bronze hinges, stainless steel hinge pins, spring-operated lifting mechanism, automatic hold-open arm with release handle.
- D. Stainless steel inside snap lock, removable key-wrench lifting handle.
- E. Finish: Standard mill finish.
- F. Shop coat portions of the frame which may contact or be embedded in concrete with a heavy coat of bituminous paint.

2.4 ANCHOR BOLTS

- A. Unless otherwise noted on the Drawings, furnish stainless steel anchor bolts and associated fasteners for interior and exterior applications. Anchor bolt sizing to be as shown on Drawings. Anchor bolt sizes not shown on Drawings shall be as recommended by manufacturer of equipment being anchored. Minimum anchor bolt length 3" with minimum 6" embedment. Provide a minimum of 1/2" bolt projection beyond anchor bolt nut. Furnish flat washer with each anchor bolt. Unless otherwise indicated, all anchor bolts to be embedded type. Set prior to concrete placement.
- B. Expansion or adhesive type anchor bolts may be utilized where indicated on the Drawings. Expansion bolts shall meet the same requirements as anchor bolts except bolts shall have a 4" minimum embedment and conform to Federal Specification FF-S-325, Group II, Type 4, Class I for concrete expansion anchors.

2.5 DUCTILE IRON PIPE

- A. See Section 33 31 13.

2.6 PIPE ACCESSORIES

- A. Wall Sleeves and Wall Pipes:
 - 1. Cast Iron: ASTM A48, Class 30B
 - 2. Ductile Iron: ASTM A536, Grade 60-40-18
 - 3. Mechanical Joint, ANSI/AWWA C111/A21.11
 - 4. Integral cast intermediate wall collar
- B. Wall Seals:
 - 1. Assembly of synthetic rubber links connected with corrosion resistant bolts; when the bolts are tightened, Delrin or Approved Equal plastic pressure plates compress the rubber links to fill the annular space between the pipe and the wall sleeve to form a watertight seal.
 - 2. All wall seals located in penetrations through new walls that are below grade shall be installed in a cast iron wall sleeve that conforms to the requirements of this specification section or installed in a steel wall sleeve. This steel wall sleeve shall consist of a piece of standard weight steel pipe with an integral steel anchoring collar. This anchoring collar shall be 1/4" thick, shall project 3" beyond the pipe outer wall and shall be welded to the pipe around its entire periphery. No sleeves are required if hole is core drilled through a new or existing concrete wall.
 - 3. Century-Line prefabricated sleeves as manufactured by the Thunderline Corporation, Belleville, Michigan, or Approved Equal may be used in lieu of steel or cast iron sleeves for wall seal application.
- C. Coupling Adapters:
 - 1. Factory pre-assembled couplings for plain-end pipe.

2. Double-ring, steel followers, rubber compounded wedge-gasketed, steel flared middle ring type mechanical joint, ANSI/AWWA C111/A21.11.

2.7 VALVES

- A. Flanged Joint Swing Check Valves: Iron body, bronze mounted, stainless steel hinge pin, horizontal swing check type. External lever with spring. Renewable disc. AWWA C508. Valves 2" to 12", 150 psi working pressure; valves 14" to 24", 175 psi working pressure. Provide rubber faced clappers. Spring tension shall be adjustable.
 1. Provide check valves designed so that all parts may be removed for inspection or replacement through the top of the valve with the valve in position.
- B. Plug Valves:
 1. Semi-steel body, flanged or mechanical joint ends. Eccentric plug, rectangular or semi-circular ports. For 4" diameter and smaller plug valves, where rectangular port is furnished, the cross-sectional area shall be not less than 100% of the connecting pipe cross-sectional area.
 2. Plug valves shall have a cast iron plug having a resilient neoprene or nitrile butadiene rubber facing. Valve bodies shall be furnished with an 1/8" minimum welded overlay seat of not less than 90% pure nickel. Seat area shall be raised, with raised surface completely covered with weld to insure that the plug face contacts only nickel. Valves shall have corrosion resistant bearing. Valve shaft seals shall be in accordance with AWWA C504 or C507. Valve housing shall be constructed such that a leak through the shaft seal is free to drain to atmosphere and will not flood the gear actuator. Valves shall have a 150 psi working pressure. Sizes 4" and smaller lever actuated; sizes 6" and larger provide with manual handwheel gear actuators.
 3. Gear Actuators:
 - a. Gearing oil lubricated, enclosed in a semi-steel sealed housing. Actuator shaft and quadrant supported on permanently lubricated bronze bearings. Stainless steel nuts, bolts, springs and washers.
 - b. Valve position indicator. Adjustable closing torque stop.
 - c. Mounting brackets for buried or submerged service totally enclosed and with gasket seals.
- C. Combination Air Valve
 1. All functions performed by the combination valve shall be housed in a single body with one inlet and one outlet connection. Inlet shall have no obstruction to restrict flow.
 2. Long Body and Cover: Ductile iron, epoxy coated.
 3. All Internal Metal Parts: Stainless steel with nitrile butadiene rubber seats for drip tight shutoff. Float capable of withstanding 750 psi test pressure.
 4. Valve shall have bronze shutoff valves, quick connect couplings and rubber hose for backwashing with clean water.
- D. Cam-locking quick-coupler. MPT coupler socket, FPT adapter plug, side levers. Stainless steel. Nitrile butadiene rubber gaskets. Meet MIL-C-27487 Specifications.

2.8 CONTROLS

- A. Refer to electrical specifications for controls

2.9 ELECTRICAL REQUIREMENTS

- A. See Division 26.

2.10 MATERIALS PROTECTION

- A. Coat pumps, pump discharge piping, and valve vault piping in accordance with specification Section 09 90 00.
- B. Shop coat the exterior of pump basin and valve vault with bitumastic compound. Koppers Bitumastic No. 50 or Approved Equal.

PART 3 EXECUTION

3.1 INSTALLATION

- A. Install the pumping equipment where indicated on the Contract Drawings and in accordance with the manufacturer's instructions and the approved shop drawings. Use wall sleeves with wall seals to seal all pipe penetrations through the pump station and valve vault walls.
- B. Provide and connect accessories, power and control conduit and wiring as required to ensure a complete operable system as intended.
- C. Obtain and provide the Owner with an Installation Certificate signed by the equipment manufacturer's representative attesting that the equipment has been properly installed and is ready for start-up and performance testing.

3.2 PRE-OPERATION CHECK

- A. Test the pump basin for leakage in accordance with Section 33 01 30.13.
- B. Make the following checks before operating pump:
 - 1. Assure that piping and basin are clear of debris which might clog pump.
 - 2. Check level switch settings.
 - 3. Check for proper motor rotation.

3.3 PERFORMANCE TESTING AND ADJUSTMENT

- A. Operate the pump station using clear water at the design point through two complete pumping cycles, under the supervision of the manufacturer's representative and in the presence of the Engineer. Check pump and motor for excessive vibration and high bearing temperatures. Demonstrate correct sequence of pump operation. Check for motor overload by taking ampere readings.
- B. Verify pump performance by timing how long it takes to drawdown a specific volume of liquid and measuring the pump discharge head with a pressure gauge. Provide written pump performance test results and pump curve to Owner.
- C. Demonstrate provision for pump removal and replacement.

3.4 EQUIPMENT ACCEPTANCE

- A. Adjust, repair, modify or replace any components which fail to perform as specified and rerun the tests. Make final adjustments under the direction of the manufacturer's representative and to the satisfaction of the Engineer.

END OF SECTION 33 32 00

SECTION 33 39 16 - LINING SYSTEMS FOR WASTEWATER STRUCTURES - Revised

PART 1 GENERAL

1.1 DESCRIPTION:

- A. This specification governs all work, materials, labor and equipment required for the installation of a comprehensive lining system for wastewater structures which restores the structure's interior surface profile, repairs voids, restores structural integrity, provides corrosion protection, and eliminates water infiltration and exfiltration.

1.2 REFERENCES

- A. American Society for Testing and Materials (ASTM):
 1. C109 - Compressive Strength Hydraulic Cement Mortars
 2. C138 - Standard Test Method for Density
 3. C267 - Chemical Resistance of Mortars, Grouts, and Monolithic Surfacing and Polymer Concretes
 4. C348 - Flexural Strength of Concrete
 5. C469 - Static Modulus of Elasticity & Poisson's Ratio of Concrete Compression
 6. C496 - Splitting Tensile Strength of Cylindrical Concrete Specimens
 7. C882 - Slant Shear Bond Strength
 8. C1090 - Shrinkage Test
 9. C1138 - Standard Test Method for Abrasion Resistance of Concrete (Underwater Method)
 10. C1202 - Electrical Indication of Concrete's Ability to Resist Chloride Ion Penetration
 11. D2240 - Hardness
 12. D4060 - Taber Abrasion (mg loss)
 13. D4414 - Wet Film Thickness Gage
 14. D7234 - Adhesion
 15. F2414 - Practice for Sealing Sewer Manhole Using Chemical Grouting

1.3 SUBMITTALS

- A. The following shall be submitted to the engineer for approval prior to commencing work:
 1. Lining system descriptive literature, bulletins and or catalogs of materials.
 2. Manufacturer's Certification of Applicator.
 3. Certified Applicator Minimum Qualifications.
 4. Technical Data Sheet on each product used.
 5. Material handling and storage requirements, mixing and proportioning requirements (as applicable), maximum pot life, film/coating thickness, curing, testing and certification requirements, and Material Safety Data Sheets (MSDS) for each product used.
 6. Material and method for repair of leaks or cracks in the structure.
 7. Description, layout, and application sequencing plan.
 8. Detailed instructions and methodology for making pipe to structure connections in conjunction with the installation of the lining system to prevent infiltration and exfiltration.
 9. Maintenance of wastewater flow capacity and/or bypass pumping plan.
 10. Confined space entry plan and permit.
 11. Plan for capturing extraneous debris during lining processes and debris disposal.

1.4 QUALITY ASSURANCE (Revised – Addendum No. 4)

- A. The applicator (company performing the installation) shall be completely trained in leak repair, surface preparation and application of the lining system.
- B. The materials/products shall be suitable for installation in a wastewater environment without any deterioration of the liner.
- C. The applicator shall be trained and provide a letter of certification from the manufacturer for the handling, mixing, application, and inspection of the liner system as described herein.
- D. To ensure total unit responsibility, all materials and installation thereof shall be furnished and coordinated by manufacturer/certified applicator.
- E. Liner and vacuum test results shall be provided immediately following testing and inspection and shall be approved prior to acceptance of the Work.

1.5 WARRANTY

- A. Applicator and Manufacturer must warrant the liner system installation against failure for a period of 10 years from the installation date. Applicator shall correct failures any time prior to 10 years after the installation date. Failure will be deemed to have occurred if the protective liner fails to: (a) prevent the internal corrosion of the structure or (b) prevent groundwater infiltration. Failure does not include damage resulting from mechanical force or the presence of chemical substances not customarily present or used in Wastewater Structures, defects in the workmanship or devices of others upon which the Wastewater Structure functions or act of God. The liner must be installed in accordance with Manufacturer's instructions by Applicators certified by Manufacturer. Executed 10-year Applicator and Manufacturer warranties are to be provided upon completion of work.

PART 2 PRODUCTS

2.1 PRODUCTS AND MATERIALS

- A. Liner Products and Materials: (Revised – Addendum No. 4)
The products and materials to be utilized in the lining of wastewater structures shall be designed and manufactured to withstand the severe effects a wastewater environment.
- B. Cementitious Mortar:
Mortar shall be made of one part Portland cement and two parts clean sharp sand. Cement shall be Type 1 and shall conform to ASTM C 150. Sand shall meet the requirements of ASTM C 144. This material shall be supplied or approved by the selected liner system manufacturer.
- C. Patching Material:
A quick setting fiber reinforced cementitious material shall be used as a patching material and is to be mixed and applied according to manufacturer's recommendations. This material shall be supplied or approved by the selected liner system manufacturer.
- D. Hydraulic Cement:
A rapid setting, high-early-strength, cementitious product specifically formulated for leak control shall be used to stop water infiltration. This material shall be supplied or approved by the selected liner system manufacturer. The material shall be mixed and applied according to the manufacturer's recommendations.
- E. Chemical Grout:
A chemical grout shall be used for stopping very active infiltration and for filling voids. This material shall be supplied or approved by the selected liner system manufacturer.

2.2 EQUIPMENT

- A. Equipment for installation of liner products and materials shall be of high quality and as recommended by the manufacturer.

2.3 APPROVED LINING SYSTEMS

The lining system to be utilized for wastewater structures shall be selected by Contractor from the following approved lining systems:

A. STRESS SKIN PANEL LINING SYSTEM

This system is a multi-layer “stress skin panel” liner system as described below:

1. Liner

Installation

Moisture barrier

Surfacer

Final corrosion barrier

Liner

Modified Polymer (Silicone modified polyurea)

Polyurethane/Polymeric blend foam

Modified polymer (Silicone modified Polyurea)

2. The Modified polymer (silicone modified polyurea) shall be sprayable, solvent free, two-component polymeric, moisture/chemical barrier specifically developed for the corrosive wastewater environment.
3. The Polyurethane Rigid Structure Foam, shall be low viscosity two-component, containing flame retardants.
4. Total thickness of multi-layer liner system shall be a minimum of 500 mils.
5. The product shall be SPECTRASHIELD, manufactured by CCI Spectrum, Inc, or equal.

B. GEOPOLYMER LINING SYSTEM (Revised – Addendum No. 4)

This system is a monolithic “geopolymer” liner system as described below:

1. Geopolymer Liner Material: Fiber reinforced geopolymer mortar made with aluminosilicate and enhanced with monocrySTALLINE quartz aggregate shall be used to form a structural monolithic liner covering all interior surfaces and shall have the following minimum requirements:
 - a. Compressive Strength (ASTM C109): 8,000 psi, 28 days
 - b. Flexural Strength (ASTM C348): 800 psi, 28 days
 - c. Tensile Strength (ASTM C496): 900 psi, 28 days
 - d. Shrinkage (ASTM C1090): 0.02% at 28 days
 - e. Slant Shear Bond Strength (ASTM C882): 3,000 psi, 28 days
2. XRF and XRD testing shall be conducted on samples of the powdered product taken onsite during the application process and results shall be provided to the Engineer.
3. The geopolymer liner system shall be applied to a minimum thickness of one inch (1”).
4. The geopolymer liner system shall be GEOKRETE, manufactured by Quadex, LLC, or approved equal.

C. RESTORATION AND CORROSION BARRIER COMPOSITE LINER

This system is a two-layer “composite” liner system as described below:

1. High-strength Restoration Mortar: The first layer the composite liner system shall be Mainstay ML-72, manufactured by Madewell Products Corporation, or approved equal. This is a high-strength restoration mortar which shall be applied to form a structural monolithic liner covering all interior surfaces and shall have the following minimum requirements:
 - a. Compressive Strength (ASTM C109): 10,000 psi, 28 days
 - b. Flexural Strength (ASTM C293): 1,400 psi, 28 days
 - c. Tensile Strength (ASTM C496): 800 psi, 28 days
 - d. Shrinkage (ASTM C596): 0.02% at 28 days
 - e. Bond Strength (ASTM C882): 2,000 psi, 28 days
 - f. Minimum thickness shall be one-half inch (0.5”) or the minimum thickness required by the manufacturer, whichever is greater.

2. Epoxy Corrosion Barrier: The second layer of the composite liner system shall be Mainstay DS-5, manufactured by Madewell Products Corporation, or approved equal. This is a 100% solids epoxy corrosion barrier coating which shall be applied over the completed high-strength restoration mortar while the mortar is still in its uncured state (soft). The corrosion barrier shall be spray applied or spin cast. The epoxy liner material shall have the following minimum requirements:
 - a. Hardness, Shore D (ASTM D2240): 85 (+/- 2)
 - b. Adhesion (ASTM D4541), Concrete: Substrate Failure
 - c. Abrasion: ASTM D 4060 – Requirement: No more than 180 mg loss after 1,000 cycles
 - d. Corrosion Resistance: Suitable for environments with a PH of 0.5 or higher
 - e. Minimum thickness of the epoxy liner shall be 125 mils, dry film thickness.
3. The composite liner system shall be MAINSTAY, manufactured by Madewell Products Corporation, or approved equal.

PART 3 EXECUTION

3.1 INITIAL INSPECTION

- A. Applicator shall take appropriate action to comply with all local, state, and federal regulations including those set forth by OSHA, EPA, the Owner and any other applicable authorities.
- B. Prior to conducting any work, an initial inspection of the structure shall be performed to determine need for protection against hazardous gases or oxygen depleted atmosphere and the need for flow control or flow diversion.
- C. If required, submit a plan for flow control or bypass to the engineer for approval prior to conducting the work.
- D. New Portland cement structures shall have endured a minimum of 28 days since manufacture prior to commencing installation of the liner system.

3.2 SURFACE PREPARATION

- A. The surface preparation program will include checking the atmosphere for hydrogen sulfide, methane, low oxygen, or other gases, approved flow control equipment, and surface preparation equipment.
- B. Surface preparation for standard manhole structures shall be in accordance with the manufacturer's recommendations, and may include high pressure water cleaning and shall provide a surface compatible for installation of the liner system.
- C. Surface preparation and methods for other structures shall be in accordance with the manufacturer's recommendations, and may include high pressure water cleaning, hydro blasting, abrasive blasting, grinding, or detergent water cleaning, and shall be suited to provide a surface compatible for installation of the liner system.
- D. The surface preparation method shall produce a cleaned, abraded and sound surface with no evidence of laitance, loose concrete, loose brick, loose mortar, contaminants or debris, and shall display a surface profile suitable for application of the liner system in accordance with the manufacturer's recommendations.
- E. After completion of surface preparation, inspecting for:
 1. Leaks
 2. Cracks
 3. Holes
 4. Exposed Rebar
 5. Ring and Cover Condition
 6. Invert Condition
 7. Inlet and Outlet Pipe Condition

- F. After the defects in the structure are identified, repair all leaks and severe cracks with products and materials recommended and approved by the liner system manufacturer.
- G. Upon completion of leak and crack repair, the surface shall be primed in accordance with the manufacturer's recommendations.

3.3 MATERIAL INSTALLATION

- A. Application procedures shall conform to recommendations of the manufacturer, including materials handling, mixing, environmental controls during application, safety and spray equipment.
- B. Spray equipment shall be specifically designed to accurately ratio and apply the liner system.
- C. Application of liner system shall be in strict accordance with manufacturer's recommendation. Final installation minimum total thickness shall be as specified in subpart 2.3. A permanent identification and date of work performed shall be affixed to the structure in a readily visible location.
- D. A final written report shall be provided to the engineer detailing the location, date of work and description of the work.

3.4 TESTING

- A. For the Stress Skin Panel Liner and the Composite Liner systems, the following tests will be required for each layer of epoxy lining material:
 - 1. Wet Film Thickness Gage: During application a wet film thickness gage, meeting ASTM D4414 – Standard Practice for Measurement of Wet Film Thickness of Organic Coatings by Notched Gages, shall be used to ensure a monolithic coating and uniform thickness during application.
 - 2. Adhesion Test: Testing shall be conducted in accordance with ASTM D7234-05 at a rate of one test for every 10 structures with a minimum of one test per project.
- B. A Vacuum Test in accordance with Section 33 01 30.13 shall be performed on each lined structure immediately following the elapsed cure time of the final layer of product or material application as recommended by the liner system manufacturer.

3.5 FINAL INSPECTION

- A. Final liner system shall be completely free of pinholes or voids. Liner thickness shall be the minimum value as specified in subpart 2.3.
- B. Visual inspection shall be made by the Engineer. Any deficiencies in the finished liner system shall be marked and repaired according to the procedures set forth by the manufacturer.

END OF SECTION 33 39 16



ST. TAMMANY PARISH

PATRICIA P. BRISTER
PARISH PRESIDENT

July 17, 2018

Please find the following addendum to the below mentioned BID.

Addendum No.: 3
Bid#: 622-10-18-31-2
Project Name: Colonial Court Lift Station Upgrade
Bid Due Date: July 24, 2018

GENERAL INFORMATION:

- 1. The mandatory Pre-Bid Conference was held Thursday, June 28, 2018 at 2:00 PM in the 3rd Floor Staff Conference Room, Building B, St. Tammany Parish Government Administrative Complex at 21454 Koop Drive, Mandeville, Louisiana 70471. Questions from the Pre-Bid and official responses are listed in the Questions & Answers section of this addendum. The Pre-Bid Sign-In Sheet is attached.**
- 2. Please REPLACE Section 01, Table of Contents with Section 01, Table of Contents – Revised (attached). Section 12, Geotechnical Report, was added.**
- 3. Please REPLACE Section 00 01 10 – Table of Contents in Section 10, Project Specifications with Section 00 01 10 – Table of Contents – Revised (attached). The Table of Contents has been revised.**
- 4. Please DELETE Section 09 96 00 – High Performance Coatings from Section 10, Project Specifications, in its entirety. The work previously covered by this section will now be covered by Section 33 39 16 – Lining Systems for Wastewater Structures (attached).**
- 5. Please REPLACE Section 33 32 00 – Sewage Pump Station in Section 10, Project Specifications with Section 33 32 00 – Sewage Pump Station – Revised (attached). Additional information has been provided in Paragraph 1.2.A and two (2) additional pump models have been added as approved equals in Paragraph 1.2.C.**
- 6. Please ADD Section 33 39 16 – Lining Systems for Wastewater Structures (attached) to Section 10, Project Specifications, after Section 33 32 00 – Sewage Pump Station. Two (2) additional Lining Systems have been added as approved equals.**



ST. TAMMANY PARISH

PATRICIA P. BRISTER
PARISH PRESIDENT

7. Please ADD the attached Geotechnical Report to the bidding documents as Section 12, Geotechnical Report, after Section 11, Project Plans.

QUESTIONS & ANSWERS:

Question #1: Does the Parish own the lot where the lift station is located?

Answer #1: Yes, the lot is owned by the Parish.

Question #2: How much of the lot is being cleared?

Answer #2: The area within the limits of construction will be cleared. The limits are currently marked on-site for the clearing crew.

Question #3: What areas can be used for lay-down?

Answer #3: The remainder of the Parish property and the street right-of-way adjacent to the site may be used for lay-down. A second location near the site at Hickory Street and Dove Park Road which is either owned by the Parish or is a drainage servitude may be used for lay-down. The Westwood Wastewater Treatment Plant is located about a quarter mile away to the south and may also be used for lay-down inside the fence. The Contractor shall notify the Parish of the areas they intend to use for lay-down.

Question #4: Is the wet well pre-cast or cast-in-place?

Answer #4: The wet well may be pre-cast or cast-in-place as addressed in Addendum No. 1. A 9' diameter precast wet well, or an 8' x 8' square wet well either pre-cast or cast-in-place will be allowed provided the Contractor submits structural and buoyancy calculations sealed by a structural engineer licensed in Louisiana.

Question #5: Are the suction lines required to be stainless steel?

Answer #5: Yes, the suction lines are required to be stainless steel. The interior of the wet well is considered a highly corrosive environment. All metallic materials located within the wet well shall be 316 stainless steel. Please refer to General Note 3, Sheet C-101R.



ST. TAMMANY PARISH

PATRICIA P. BRISTER
PARISH PRESIDENT

Question #6: Who pays for the testing lab?

Answer #6: Per the bidding documents, the Contractor is responsible for retaining and paying costs for testing.

Question #7: Is there a cost for disposal of materials such as permitting?

Answer #7: The cost of disposal of materials including but not limited to excess fill, sanitary waste, demolition debris, etc. will be entirely borne by the Contractor. Whether any permits are required will depend on the method of disposal. Any required permits will be the responsibility of the Contractor. A Certificate of Disposal attesting that all materials were properly disposed of will be required for each disposal location. Please refer to Section 10, Project Specifications, Section 02 41 13 – Site Demolition, Sub-Part 1.2 – Submittals.

Question #8: When will an NTP be issued?

Answer #8: The Notice to Proceed (NTP) will be issued in accordance with Section 8, General Conditions for St. Tammany Parish Government.

Question #9: How is the project funded?

Answer #9: The project is funded by the Department of Environmental Services Annual Capital Improvement Budget with no State or Federal funding sources.

Question #10: Is pre-approval required for alternate pumps?

Answer #10: Yes, pre-approval is required for alternate pumps. Despite any prior indications to the contrary, including at the Pre-Bid Meeting, pre-approval is required for all requests for use of alternate manufacturers not indicated in the specifications. Please refer to Section 8, General Conditions for St. Tammany Parish Government.

Question #11: How do we go about getting pre-approval?

Answer #11: Requests for pre-approval must be submitted to the Parish Procurement Department per the bidding documents. Documentation indicating satisfaction of all of the requirements of the appropriate specifications section must be included.



ST. TAMMANY PARISH

PATRICIA P. BRISTER
PARISH PRESIDENT

- Question #12:** If a pump is pre-approved will everyone know?
Answer #12: Yes, pre-approved equal items will be issued in an addendum.
- Question #13:** I didn't get the addendum, how do I get a copy?
Answer #13: Addenda are provided to all plan holders, uploaded to Bid Express, uploaded to the Parish website, www.stpgov.org, and hard copies are available in the Parish Procurement Department.
- Question #14:** Is the site accessible for a site visit?
Answer #14: Yes, the site is accessible however the existing lift station is behind a locked fence. Contact Tammany Utilities if you would like to request access to the existing lift station.
- Question #15:** Will the wet well be required to be coated with protective coating?
Answer #15: Yes, please refer to Section 11, Project Plans, Sheet C-101R – Site Plan, General Note 4.
- Question #16:** Are there soil borings for this project?
Answer #16: Yes, please refer to Section 12, Geotechnical Report (attached).
- Question #17:** For the new wet well, someone asked if we could use an 8'x8' in lieu of 9' diameter. In the addendum, it states that we could go with cast-in-place 8'x8'. Was this meant to be precast?
Answer #17: Please refer to Question and Answer #4.
- Question #18:** Will the Parish accept Wastecorp Pumps model TFCH-6 as equal to the pumps specified?
Answer #18: Yes. Please refer to Section 10, Project Specifications Section 33 32 00 – Sewage Pump Station – Revised (attached). By approving this product, the Parish does not waive any requirements of the technical specifications.
- Question #19:** Will the Parish accept Crane Pumps model PO6LC-14X (1600 RPM, 14" impeller diameter) as an equal to the pumps specified?
Answer #19: Yes. Please refer to Section 10, Project Specifications Section 33 32 00 – Sewage Pump Station – Revised (attached). By approving this product, the Parish does not waive any requirements of the technical specifications.



ST. TAMMANY PARISH

PATRICIA P. BRISTER
PARISH PRESIDENT

Question #20: Will the Parish accept a reduction in motor horsepower from 60 HP to 50 HP for any of the specified or approved equal pumps?

Answer #20: No. Motors must be non-overloading for the entire operational range specified. Please refer to Section 10, Project Specifications Section 33 32 00 – Sewage Pump Station – Revised (attached).

Question #21: Will the Parish accept the Mainstay Composite Liner system by Madewell Products Corporation as equal to the manhole lining system specified?

Answer #21: Yes. Please refer to Section 10 Project Specifications Section 33 39 16 – Lining Systems for Wastewater Structures (attached). By approving this product, the Parish does not waive any requirements of the technical specifications.

Question #22: Will the Parish accept the Geokrete Manhole Rehabilitation system by Quadex Repair Materials as equal to the manhole lining system specified?

Answer #22: Yes. Please refer to Section 10 Project Specifications Section 33 39 16 – Lining Systems for Wastewater Structures (attached). By approving this product, the Parish does not waive any requirements of the technical specifications.

ATTACHMENTS:

1. Pre-Bid Sign-In Sheet.pdf
2. Section 01 - Table of Contents – Revised.pdf
3. Section 10 Project Specifications, Section 00 01 10 – Table of Contents – Revised.pdf
4. Section 10 Project Specifications, Section 33 32 00 – Sewage Pump Station – Revised.pdf
5. Section 10 Project Specifications, Section 33 39 16 – Lining Systems for Wastewater Structures.pdf
6. Section 12 - Geotechnical Report.pdf

<< End of Addendum # 3 >>

Staff Conference Room, 3rd Floor
Building B, STPG Admin Complex,
21454 Koop Dr., Mandeville, LA 70471

Pre-Bid Sign-In Sheet
COLONIAL COURT LIFT STATION UPGRADE

	Name	Company	Email	Phone	Time In	Time Out
1	Stephanie Thompson	Volute, Inc.	Dennis@coastalvolute.com Steph@coastalvolute.com	985-876-6187	1:51	2:18
2	Denise Wilson	Gulf Coast Underground, LLC	d.wilson@gulfcoastunderground.com	251-725-0200	1:52	2:10
3	Daniel Mays	Consolidated Pipe & Supply	dmcays@consolidatedpipe.com	504-913-6898	1:52	1:13
4	Kenneth Koubigre	Magnolia Const.	Kkoubigre@magconst.com	205-355-7787	1:54	2:18
5	Brian Dunn	B&K Construction Company, LLC	bdunn@bkconst.com	985-626-1866	1:54	2:18
6	Luke Andrews	B&K Construction Company, LLC	Luke@bkconst.com	985-626-1866	1:55	2:19
7	Karl Gottfried	GOTTFRIED CONTRACTING	Kg3@gottfried-us.com	985-893-3773	1:55	2:19
8	Marcus Crowl	McDonald Const.	Ksmcdona@bllsouth.net	985-641-8621	1:56	2:19
9	TIM MANN	Stranco, L.L.C.	TMANN@STRANCO.NET	985-630-4667	2:01	2:21
10	Keagon Gillihan	DNA Underground, LLC.	Keagon.gillihan@gmail.com	888-284-5049	2:00	2:20
11	Sean Riley	Sherwin Williams	Sean.riley@sherwin.com	985-290-0066	2:00	2:20
12	Brad Burt	Thomas Pump & Machinery	bradb@thomaspump.com	985-649-3000	1:55	2:20
13	EVAN CONAWEY	Subterranean Const. LLC	econaway@subtlc.com	985-246-6767	2:00	2:20

	Name	Company	Email	Phone	Time In	Time Out
14	MIRA PARRA	Buchart Horn, Inc.	mparra@bucharthorn.com	(225) 372 7157	2:00	2:21
15	Beth Warren	STPG	ewarren@stpg.org	985 898 2520	1:50	2:21
16						
17						
18						
19						
20						
21						
22						
23						
24						
25						
26						
27						
28						

Section 01

Table of Contents – Revised

Section 01	Table of Contents <small>(revised – Addendum 3)</small>
Section 02	Instructions to Bidders
Section 03	Summary of Work
Section 04	LA Uniform Public Work Bid Form
Section 05	Affidavits, Louisiana (Pursuant to LSA-R.S. 38:2224, 38:2227 and 38:2212.10)
Section 06	Insurance Requirements
Section 07	Project Sign
Section 08	General Conditions
Section 09	Contract Time Extension Specifications
Section 10	Project Specifications <small>(revised – Addenda 1 & 3)</small>
Section 11	Project Plans <small>(revised – Addendum 1)</small>
Section 12	Geotechnical Report <small>(new – Addendum 3)</small>

Section 10
Project Specifications

SECTION 00 01 10 - TABLE OF CONTENTS - Revised

PROCUREMENT AND CONTRACTING REQUIREMENTS

SPECIFICATIONS

Division 02 -- Existing Conditions

02 41 13 - Site Demolition

Division 03 -- Concrete

03 30 00 - Cast-in-Place Concrete

03 60 00 - Grout

Division 09 -- Finishes

09 90 00 - Painting

Division 25 -- Integrated Automation

25 02 00 - Control Panel

Division 26 -- Electrical

26 05 01 - Electrical Demolition

26 05 19 - Low-Voltage Electrical Power Conductors and Cables

26 05 26 - Grounding and Bonding for Electrical Systems

26 05 29 - Hangers and Supports for Electrical Systems

26 05 34 - Conduit

26 05 37 - Boxes

26 05 53 - Identification for Electrical Systems

26 21 00 - Low-Voltage Electrical Service Entrance

26 28 16.16 - Enclosed Switches

26 36 00 - Transfer Switches

26 56 00 - Exterior Lighting

Division 31 -- Earthwork

31 20 00 - Earthwork

31 23 17 - Trenching, Backfilling and Compacting

Division 33 -- Utilities

33 01 30.13 - Sewer and Manhole Testing

33 31 13 - Sanitary Sewer Pipe (revised - Addendum 1)

33 32 00 - Sewage Pump Station (revised - Addendum 3)

33 39 16 - Lining Systems for Wastewater Structures (new - Addendum 3)

END OF SECTION 00 01 10

SECTION 33 32 00 - SEWAGE PUMP STATION - Revised

PART 1 GENERAL

1.1 DESCRIPTION

- A. The Work of this section includes, but is not limited to, sewage pump station with wet well, self-priming centrifugal solids handling pumps, piping, valves, and all appurtenances for a complete installation.
- B. Related Work specified elsewhere:
 - 1. Section 03 30 00 - Cast-In-Place Concrete
 - 2. Section 03 60 00 - Grout
 - 3. Section 09 90 00 - Painting
 - 4. Section 31 20 00 - Earthwork
 - 5. Section 31 23 17 - Trenching, Backfilling & Compacting
 - 6. Section 33 31 13 - Sanitary Sewer Pipe

1.2 QUALITY ASSURANCE (Revised – Addendum No. 3)

- A. Self-Priming Centrifugal Pump Design Criteria (each pump):
 - 1. Capacity: 706 GPM @ 142' TDH Design Point
<500 gpm @ >156' TDH Shutoff
>900 gpm @ <134' TDH Runout
 - 2. Motor: 60 HP minimum
Non-overloading @ entire range
480 V, 3-phase, 60 Hz
 - 3. Pump Discharge: 4" diameter minimum
- B. All electrical equipment to be installed must meet the requirements of Article 500, "Hazardous Locations", of the National Electric Code (NEC) of the National Fire Protection Association (NFPA), or "NEC-500". All electrical equipment installed inside the wet well or within three feet (3') of the wet well vent must be UL approved to meet the requirements for use in Class 1, Group D, Division 1 locations as defined in NEC-500. All electrical equipment installed within three feet (3') of the wet well hatch or within five feet (5') of the wet well vent must be UL approved to meet the requirements for use in Class 1, Group D, Division 2 locations as defined in NEC-500.
- C. Both pumps shall be of the same manufacturer and model which shall be one of the following:
 - 1. Gorman-Rupp model V4A-B-1;
 - a. impeller diameter: 9.75"
 - b. pump discharge: 4"
 - c. pump speed: 2385 RPM
 - d. speed ratio = 1:1.36
 - 2. Wastecorp Pumps model TFCH-6;
 - a. impeller diameter: 12.50"
 - b. pump discharge: 6"
 - c. pump speed: 1750 RPM
 - d. speed ratio = 1:1 (drive transmission not required)
 - 3. Crown Pumps model PO6LC-14X;
 - a. impeller diameter: 14.00"
 - b. pump discharge: 6"
 - c. pump speed: 1600 RPM
 - d. speed ratio = 1.09:1
 - 4. Approved Equal.

1.3 SUBMITTALS

- A. Equipment Certification: At the time of submitting shop drawings, submit the equipment manufacturer's warranty and certification attesting that the manufacturer has examined the Contract Drawings and Specifications and that the equipment provided will meet the performance criteria and conforms to specification requirements.
- B. Shop Drawings and Product Data:
 - 1. Submit the required number of copies of certified detailed installation shop drawings for basin assembly, pumps, piping, controls and accessories including wiring schematics.
 - 2. Submit manufacturer's latest published literature for all materials specified under this Section.
 - 3. Before shipment, submit certified pump curves showing head/capacity relationships after pump assemblies have been fabricated and performance tested at the factory. Submit certified results of all start-up and performance tests.
 - 4. Submit calculations for the wet well and valve vault which verify that each structure's weight is sufficient to counteract hydrostatic uplift using a 1.5 safety factor.
- C. Maintenance Data and Operating Instructions: At time of delivery, submit the required number of copies of Operation and Maintenance Manuals for the pump station furnished including a detailed description of the operation of each principal component, procedures for operation, instructions for overhaul and maintenance, lubrication schedule, safety precautions, test procedures, and parts lists.
- D. Maintenance Material (Spare Parts):
 - 1. At time of delivery, provide one complete set of manufacturer's recommended spare parts for each pump and motor assembly, including pump mechanical seals, bearings, bushings and gaskets.
 - 2. Package each part individually or in sets in moisture-proof containers or wrappings, clearly labeled with part name and manufacturer's part/stock number.
 - 3. Provide any special tools required for equipment maintenance.

1.4 FIELD SERVICES

- A. Provide the services of a manufacturer's representative experienced in the installation and operation of the pumping station supplied under this specification for not less than two 8-hour workdays on-site for installation inspection, start-up, and instructing Owner's operating personnel.
- B. Provide for the above services to be performed during two separate visits to the project site.

PART 2 PRODUCTS

2.1 SELF-PRIMING CENTRIFUGAL PUMPS (Revised – Addendum No. 3)

- A. Pump shall be horizontal, belt driven self-priming centrifugal type, designed specifically for handling raw unscreened domestic sanitary sewage or industrial waste.
- B. Materials and Construction Features
 - 1. Pump casing shall be cast iron Class 30 with integral volute scroll. Casing shall incorporate following features:
 - a. Mounting feet sized to prevent tipping or binding when pump is completely disassembled for maintenance.
 - b. Fill port cover plate, 3 1/2" diameter, shall be opened after loosening a positive lock clamp bar assembly. In consideration for safety, cap screw threads must provide slow release of pressure, and the clamp bar shall be retained by detente lugs. A non-metallic gasket shall prevent adhesion of the fill port cover to the casing while assuring a reliable seal.
 - c. Casing drain plug shall be at least 1 1/4" NPT to insure complete and rapid draining.
 - d. Liquid volume and recirculation port design shall be consistent with performance criteria listed under PART 1 - GENERAL of this section.

2. Cover plate shall be cast iron Class 30. Design must incorporate the following maintenance features:
 - a. Retained by acorn nuts for complete access to pump interior. Cover plate removal must provide ample clearance for removal of stoppages, and allow service to the impeller, seal, wear plate or check valve without removing suction or discharge piping.
 - b. A replaceable wear plate secured to the cover plate by weld studs and nuts shall be AISI 1015 HRS. Wear plate shall be self-cleaning design ensuring that debris is cleared away and does not collect on the impeller vanes.
 - c. Pressure relief valve shall be supplied in the cover plate. Relief valve shall open at 75-200 PSI.
 - d. Two O-rings of nitrile butadiene rubber material shall seal cover plate to pump casing.
 - e. Pusher bolt capability to assist in removal of cover plate. Pusher bolt threaded holes shall be sized to accept same retaining cap screws as used in rotating assembly.
 - f. Easy-grip handle shall be mounted to face of cover plate.
3. Rotating assembly, which includes impeller, shaft, mechanical shaft seal, lip seals, bearings, seal plate and bearing housing, must be removable as a single unit without disturbing the pump casing or piping. Design shall incorporate the following features:
 - a. Seal plate and bearing housing shall be cast iron Class 30. Anti-rotation ribs shall be cast into the seal plate to reduce internal wear and maximize component life. Separate oil filled cavities, vented to atmosphere, shall be provided for shaft seal and bearings. Cavities must be cooled by the liquid pumped. Three lip seals will prevent leakage of oil.
 - 1) The bearing cavity shall have an oil level sight gauge and fill plug check valve. The clear sight gauge shall provide easy monitoring of the bearing cavity oil level and condition of oil without removal of the fill plug check valve. The check valve shall vent the cavity but prevent introduction of moist air to the bearings.
 - 2) The seal cavity shall have an oil level sight gauge and fill/vent plug. The clear sight gauge shall provide easy monitoring of the seal cavity oil level and condition of oil without removal of the fill/vent plug.
 - 3) Double lip seal shall provide an atmospheric path providing positive protection of bearings, with capability for external drainage monitoring.
 - b. Impeller shall be ductile iron, two vane, semi-open, non-clog, with integral pump out vanes on the back shroud. Impeller shall be statically or dynamically balanced. Impeller shall thread onto the pump shaft and be secured with a lock screw and conical washer.
 - c. Shaft shall be AISI 4140 alloy steel unless otherwise specified by the engineer, in which case AISI 17-4 pH stainless steel shall be supplied.
 - d. Bearings shall be anti-friction ball type of proper size and design to withstand all radial and thrust loads expected during normal operation. Bearings shall be oil lubricated from a dedicated reservoir. Pump designs which use the same oil to lubricate the bearings and shaft seal shall not be acceptable.
 - e. Shaft seal shall be oil lubricated mechanical type. The stationary and rotating seal faces shall be silicon carbide alloy. Each mating surface shall be lapped to within three light bands flatness (35 millionths of an inch), as measured by an optical flat under monochromatic light. The stationary seal seat shall be double floating by virtue of a dual O-ring design. An external O-ring secures the stationary seat to the seal plate, and an internal O-ring holds the faces in alignment during periods of mechanical or hydraulic shock (loads which cause shaft deflection, vibration, and axial/radial movement). Elastomers shall be Viton or an approved equal; cage and spring to be stainless steel. Seal shall be oil lubricated from a dedicated reservoir. The same oil shall not lubricate both shaft seal and shaft bearings. Seal shall be warranted in accordance with requirements listed under PART 1 - GENERAL of this section.
 - f. Pusher bolt capability to assist in removal of rotating assembly. Pusher bolt threaded holes shall be sized to accept same cap screws as used for retaining rotating assembly.

4. Adjustment of the impeller face clearance (distance between impeller and wear plate) shall be accomplished by external means.
 - a. Clearances shall be maintained by a four point external shimless cover plate adjustment system, utilizing a four collar and four adjusting screw design allowing for incremental adjustment of clearances by hand as required. Each of the four points shall be lockable to prevent inadvertent clearance increases or decreases due to equipment vibration or accidental operator contact. The four point system also allows for equal clearance gaps at all points between the impeller and wear plate. Requirement of realignment of belts, couplings, etc., shall not be acceptable. Cover plate shall be capable of being removed without disturbing clearance settings. Clearance adjustment systems that utilize less than four points will not be considered.
 - b. There shall be provisions for additional clearance adjustment in the event that adjustment tolerances have been depleted from the cover plate side of the pump. The removal of stainless steel shims from the rotating assembly side of the pump shall allow for further adjustment as described above.
 - c. Clearance adjustment which requires movement of the shaft only, thereby adversely affecting seal working length or impeller back clearance, shall not be acceptable.
 5. An externally removable suction check valve shall be molded Neoprene with integral steel and nylon reinforcement. A blow-out center shall protect pump casing from hydraulic shock or excessive pressure. Removal or installation of the check valve must be accomplished from the top of pump without disturbing the suction piping or completely draining the casing. Sole function of check valve shall be to save energy by eliminating need to reprime after each pumping cycle. Pumps requiring a suction check valve to assist reprime will not be acceptable.
 6. Pump shall include flange kit consisting of two ASA spool flanges that shall be one piece cast iron class 30 suitable for attachment to suction and discharge ports. Each spool shall have one 1-1/4" NPT and one 1/4" NPT tapped hole with pipe plugs for mounting gauges or other equipment.
 7. Pump manufacturer shall provide belt drive required to meet the design criteria.
- C. Serviceability
1. The pump manufacturer shall demonstrate to the engineer's satisfaction that consideration has been given to reducing maintenance costs by incorporating the following features.
 2. No special tools shall be required for replacement of any components within the pump.
- D. Drive Transmission (if required)
1. Power to pumps transmitted V-belt drive assemblies. The sheave/belt combination shall provide the speed ratio needed to achieve the specified pump operating conditions.
 2. Each drive assembly shall utilize at least two V-belts providing minimum a combined safety factor of 1.5. Computation of safety factors shall be based on performance data published by the drive manufacturer.
 3. Precise alignment tolerances of the drive assemblies shall be achieved by means of a belt/sheave alignment system resulting in the reduction of vibration, accelerated wear, and premature failure.
 4. The pump supplier shall submit power transmission calculations which document the following:
 - a. Ratio of pump/motor speed.
 - b. Pitch diameter of driver and driven sheaves.
 - c. Number of belts required per drive.
 - d. Theoretical horsepower transmitted per belt, based on vendor's data.
 - e. Center distance between pump and motor shafts.
 - f. Service factor applied to established design horsepower.
 - g. Safety factor ratio of power transmitted/brake horsepower required.
 5. Pump drives to be enclosed on all sides by a guard.
 - a. Guards must be completely removal without interference from any unit component and shall be securely fastened and braced to the unit base.

- E. Motors
 - 1. Pump motors shall be 60 HP, 3 phase, 60 hertz, 460 VAC, horizontal OTEFC 1800 RPM, NEMA design B with cast iron frame with copper windings, induction type, with class F insulation and 1.15 SF for normal starting torque and low starting current characteristics, suitable for continuous service. The motors shall not overload at the design condition or at any head in the operating range as specified.

2.2 WET WELL

- A. Cast-In-Place concrete construction in accordance with Section 03 30 00 of these Specifications.

2.3 WET WELL ACCESS HATCHES

- A. Aluminum, flush, channel frame type. Valve vault hatch shall be single leaf. Wet well hatch shall be single or double leaf. Access hatch shall open so as not to interfere with pump lift out.
- B. 1/4" extruded aluminum channel frame with anchoring flange. 1-1/2" channel drain.
- C. Minimum 1/4" thick diamond checkered aluminum plate covers, designed for minimum 300 lbs/sq.ft. loading. Heavy bronze hinges, stainless steel hinge pins, spring-operated lifting mechanism, automatic hold-open arm with release handle.
- D. Stainless steel inside snap lock, removable key-wrench lifting handle.
- E. Finish: Standard mill finish.
- F. Shop coat portions of the frame which may contact or be embedded in concrete with a heavy coat of bituminous paint.

2.4 ANCHOR BOLTS

- A. Unless otherwise noted on the Drawings, furnish stainless steel anchor bolts and associated fasteners for interior and exterior applications. Anchor bolt sizing to be as shown on Drawings. Anchor bolt sizes not shown on Drawings shall be as recommended by manufacturer of equipment being anchored. Minimum anchor bolt length 3" with minimum 6" embedment. Provide a minimum of 1/2" bolt projection beyond anchor bolt nut. Furnish flat washer with each anchor bolt. Unless otherwise indicated, all anchor bolts to be embedded type. Set prior to concrete placement.
- B. Expansion or adhesive type anchor bolts may be utilized where indicated on the Drawings. Expansion bolts shall meet the same requirements as anchor bolts except bolts shall have a 4" minimum embedment and conform to Federal Specification FF-S-325, Group II, Type 4, Class I for concrete expansion anchors.

2.5 DUCTILE IRON PIPE

- A. See Section 33 31 13.

2.6 PIPE ACCESSORIES

- A. Wall Sleeves and Wall Pipes:
 - 1. Cast Iron: ASTM A48, Class 30B
 - 2. Ductile Iron: ASTM A536, Grade 60-40-18
 - 3. Mechanical Joint, ANSI/AWWA C111/A21.11
 - 4. Integral cast intermediate wall collar
- B. Wall Seals:
 - 1. Assembly of synthetic rubber links connected with corrosion resistant bolts; when the bolts are tightened, Delrin or Approved Equal plastic pressure plates compress the rubber links to fill the annular space between the pipe and the wall sleeve to form a watertight seal.

2. All wall seals located in penetrations through new walls that are below grade shall be installed in a cast iron wall sleeve that conforms to the requirements of this specification section or installed in a steel wall sleeve. This steel wall sleeve shall consist of a piece of standard weight steel pipe with an integral steel anchoring collar. This anchoring collar shall be 1/4" thick, shall project 3" beyond the pipe outer wall and shall be welded to the pipe around its entire periphery. No sleeves are required if hole is core drilled through a new or existing concrete wall.
 3. Century-Line prefabricated sleeves as manufactured by the Thunderline Corporation, Belleville, Michigan, or Approved Equal may be used in lieu of steel or cast iron sleeves for wall seal application.
- C. Coupling Adapters:
1. Factory pre-assembled couplings for plain-end pipe.
 2. Double-ring, steel followers, rubber compounded wedge-gasketed, steel flared middle ring type mechanical joint, ANSI/AWWA C111/A21.11.

2.7 VALVES

- A. Flanged Joint Swing Check Valves: Iron body, bronze mounted, stainless steel hinge pin, horizontal swing check type. External lever with spring. Renewable disc. AWWA C508. Valves 2" to 12", 150 psi working pressure; valves 14" to 24", 175 psi working pressure. Provide rubber faced clappers. Spring tension shall be adjustable.
1. Provide check valves designed so that all parts may be removed for inspection or replacement through the top of the valve with the valve in position.
- B. Plug Valves:
1. Semi-steel body, flanged or mechanical joint ends. Eccentric plug, rectangular or semi-circular ports. For 4" diameter and smaller plug valves, where rectangular port is furnished, the cross-sectional area shall be not less than 100% of the connecting pipe cross-sectional area.
 2. Plug valves shall have a cast iron plug having a resilient neoprene or nitrile butadiene rubber facing. Valve bodies shall be furnished with an 1/8" minimum welded overlay seat of not less than 90% pure nickel. Seat area shall be raised, with raised surface completely covered with weld to insure that the plug face contacts only nickel. Valves shall have corrosion resistant bearing. Valve shaft seals shall be in accordance with AWWA C504 or C507. Valve housing shall be constructed such that a leak through the shaft seal is free to drain to atmosphere and will not flood the gear actuator. Valves shall have a 150 psi working pressure. Sizes 4" and smaller lever actuated; sizes 6" and larger provide with manual handwheel gear actuators.
 3. Gear Actuators:
 - a. Gearing oil lubricated, enclosed in a semi-steel sealed housing. Actuator shaft and quadrant supported on permanently lubricated bronze bearings. Stainless steel nuts, bolts, springs and washers.
 - b. Valve position indicator. Adjustable closing torque stop.
 - c. Mounting brackets for buried or submerged service totally enclosed and with gasket seals.
- C. Combination Air Valve
1. All functions performed by the combination valve shall be housed in a single body with one inlet and one outlet connection. Inlet shall have no obstruction to restrict flow.
 2. Long Body and Cover: Ductile iron, epoxy coated.
 3. All Internal Metal Parts: Stainless steel with nitrile butadiene rubber seats for drip tight shutoff. Float capable of withstanding 750 psi test pressure.
 4. Valve shall have bronze shutoff valves, quick connect couplings and rubber hose for backwashing with clean water.
- D. Cam-locking quick-coupler. MPT coupler socket, FPT adapter plug, side levers. Stainless steel. Nitrile butadiene rubber gaskets. Meet MIL-C-27487 Specifications.

2.8 CONTROLS

- A. Refer to electrical specifications for controls

2.9 ELECTRICAL REQUIREMENTS

- A. See Division 26.

2.10 MATERIALS PROTECTION

- A. Coat pumps, pump discharge piping, and valve vault piping in accordance with specification Section 09 90 00.
- B. Shop coat the exterior of pump basin and valve vault with bitumastic compound. Koppers Bitumastic No. 50 or Approved Equal.

PART 3 EXECUTION

3.1 INSTALLATION

- A. Install the pumping equipment where indicated on the Contract Drawings and in accordance with the manufacturer's instructions and the approved shop drawings. Use wall sleeves with wall seals to seal all pipe penetrations through the pump station and valve vault walls.
- B. Provide and connect accessories, power and control conduit and wiring as required to ensure a complete operable system as intended.
- C. Obtain and provide the Owner with an Installation Certificate signed by the equipment manufacturer's representative attesting that the equipment has been properly installed and is ready for start-up and performance testing.

3.2 PRE-OPERATION CHECK

- A. Test the pump basin for leakage in accordance with Section 33 01 30.13.
- B. Make the following checks before operating pump:
 - 1. Assure that piping and basin are clear of debris which might clog pump.
 - 2. Check level switch settings.
 - 3. Check for proper motor rotation.

3.3 PERFORMANCE TESTING AND ADJUSTMENT

- A. Operate the pump station using clear water at the design point through two complete pumping cycles, under the supervision of the manufacturer's representative and in the presence of the Engineer. Check pump and motor for excessive vibration and high bearing temperatures. Demonstrate correct sequence of pump operation. Check for motor overload by taking ampere readings.
- B. Verify pump performance by timing how long it takes to drawdown a specific volume of liquid and measuring the pump discharge head with a pressure gauge. Provide written pump performance test results and pump curve to Owner.
- C. Demonstrate provision for pump removal and replacement.

3.4 EQUIPMENT ACCEPTANCE

- A. Adjust, repair, modify or replace any components which fail to perform as specified and rerun the tests. Make final adjustments under the direction of the manufacturer's representative and to the satisfaction of the Engineer.

END OF SECTION 33 32 00

SECTION 33 39 16 - LINING SYSTEMS FOR WASTEWATER STRUCTURES

PART 1 GENERAL

1.1 DESCRIPTION:

- A. This specification governs all work, materials, labor and equipment required for the installation of a comprehensive lining system for wastewater structures which restores the structure's interior surface profile, repairs voids, restores structural integrity, provides corrosion protection, and eliminates water infiltration and exfiltration.

1.2 REFERENCES

- A. American Society for Testing and Materials (ASTM):
1. C109 - Compressive Strength Hydraulic Cement Mortars
 2. C138 - Standard Test Method for Density
 3. C267 - Chemical Resistance of Mortars, Grouts, and Monolithic Surfacing and Polymer Concretes
 4. C348 - Flexural Strength of Concrete
 5. C469 - Static Modulus of Elasticity & Poisson's Ratio of Concrete Compression
 6. C496 - Splitting Tensile Strength of Cylindrical Concrete Specimens
 7. C882 - Slant Shear Bond Strength
 8. C1090 - Shrinkage Test
 9. C1138 - Standard Test Method for Abrasion Resistance of Concrete (Underwater Method)
 10. C1202 - Electrical Indication of Concrete's Ability to Resist Chloride Ion Penetration
 11. D2240 - Hardness
 12. D4060 - Taber Abrasion (mg loss)
 13. D4414 - Wet Film Thickness Gage
 14. D7234 - Adhesion
 15. F2414 - Practice for Sealing Sewer Manhole Using Chemical Grouting

1.3 SUBMITTALS

- A. The following shall be submitted to the engineer for approval prior to commencing work:
1. Lining system descriptive literature, bulletins and or catalogs of materials.
 2. Manufacturer's Certification of Applicator.
 3. Certified Applicator Minimum Qualifications.
 4. Technical Data Sheet on each product used.
 5. Material handling and storage requirements, mixing and proportioning requirements (as applicable), maximum pot life, film/coating thickness, curing, testing and certification requirements, and Material Safety Data Sheets (MSDS) for each product used.
 6. Material and method for repair of leaks or cracks in the structure.
 7. Description, layout, and application sequencing plan.
 8. Detailed instructions and methodology for making pipe to structure connections in conjunction with the installation of the lining system to prevent infiltration and exfiltration.
 9. Maintenance of wastewater flow capacity and/or bypass pumping plan.
 10. Confined space entry plan and permit.
 11. Plan for capturing extraneous debris during lining processes and debris disposal.

1.4 QUALITY ASSURANCE

- A. The manufacturer of the total lining system for wastewater structures shall be a company that specializes in the design and manufacture of corrosion protection materials / systems for wastewater structures.

- B. The applicator (company performing the installation) shall be completely trained in leak repair, surface preparation and application of the lining system.
- C. The materials/products shall be suitable for installation in a wastewater environment without any deterioration of the liner.
- D. The applicator shall be trained and provide a letter of certification from the manufacturer for the handling, mixing, application, and inspection of the liner system as described herein.
- E. To ensure total unit responsibility, all materials and installation thereof shall be furnished and coordinated by manufacturer/certified applicator.
- F. Liner and vacuum test results shall be provided immediately following testing and inspection and shall be approved prior to acceptance of the Work.

1.5 WARRANTY

- A. Applicator and Manufacturer must warrant the liner system installation against failure for a period of 10 years from the installation date. Applicator shall correct failures any time prior to 10 years after the installation date. Failure will be deemed to have occurred if the protective liner fails to: (a) prevent the internal corrosion of the structure or (b) prevent groundwater infiltration. Failure does not include damage resulting from mechanical force or the presence of chemical substances not customarily present or used in Wastewater Structures, defects in the workmanship or devices of others upon which the Wastewater Structure functions or act of God. The liner must be installed in accordance with Manufacturer's instructions by Applicators certified by Manufacturer. Executed 10-year Applicator and Manufacturer warranties are to be provided upon completion of work.

PART 2 PRODUCTS

2.1 PRODUCTS AND MATERIALS

- A. Liner Products and Materials:
The products and materials to be utilized in the lining of wastewater structures shall be designed and manufactured to withstand the severe effects a wastewater environment. The products and materials shall have a proven history of performance in the lining of wastewater structures for a minimum of 10 years under similar conditions. The manufacturer of the products and materials shall have at least 10 years of experience in the production of the products and materials utilized, and the products and materials shall have satisfactory installation record.
- B. Cementitious Mortar:
Mortar shall be made of one part Portland cement and two parts clean sharp sand. Cement shall be Type 1 and shall conform to ASTM C 150. Sand shall meet the requirements of ASTM C 144. This material shall be supplied or approved by the selected liner system manufacturer.
- C. Patching Material:
A quick setting fiber reinforced cementitious material shall be used as a patching material and is to be mixed and applied according to manufacturer's recommendations. This material shall be supplied or approved by the selected liner system manufacturer.
- D. Hydraulic Cement:
A rapid setting, high-early-strength, cementitious product specifically formulated for leak control shall be used to stop water infiltration. This material shall be supplied or approved by the selected liner system manufacturer. The material shall be mixed and applied according to the manufacturer's recommendations.
- E. Chemical Grout:
A chemical grout shall be used for stopping very active infiltration and for filling voids. This material shall be supplied or approved by the selected liner system manufacturer.

2.2 EQUIPMENT

- A. Equipment for installation of liner products and materials shall be of high quality and as recommended by the manufacturer.

2.3 APPROVED LINING SYSTEMS

The lining system to be utilized for wastewater structures shall be selected by Contractor from the following approved lining systems:

A. STRESS SKIN PANEL LINING SYSTEM

This system is a multi-layer "stress skin panel" liner system as described below:

1. Liner

Installation

Moisture barrier

Surfacer

Final corrosion barrier

Liner

Modified Polymer (Silicone modified polyurea)

Polyurethane/Polymeric blend foam

Modified polymer (Silicone modified Polyurea)

2. The Modified polymer (silicone modified polyurea) shall be sprayable, solvent free, two-component polymeric, moisture/chemical barrier specifically developed for the corrosive wastewater environment.
3. The Polyurethane Rigid Structure Foam, shall be low viscosity two-component, containing flame retardants.
4. Total thickness of multi-layer liner system shall be a minimum of 500 mils.
5. The product shall be SPECTRASHIELD, manufactured by CCI Spectrum, Inc, or equal.

B. GEOPOLYMER LINING SYSTEM

This system is a monolithic "geopolymer" liner system as described below:

1. Cementitious (Calcium Aluminate) Liner Material: Cementitious liner products made with calcium aluminate cement shall be used to form a structural monolithic liner covering all interior surfaces and shall have the following minimum requirements:
- a. Compressive Strength (ASTM C109): 8,000 psi, 28 days
 - b. Flexural Strength (ASTM C348): 800 psi, 28 days
 - c. Tensile Strength (ASTM C496): 900 psi, 28 days
 - d. Shrinkage (ASTM C1090): 0.02% at 28 days
 - e. Slant Shear Bond Strength (ASTM C882): 3,000 psi, 28 days
2. XRF and XRD testing shall be conducted on samples of the powdered product taken onsite during the application process and results shall be provided to the Engineer.
3. The geopolymer liner system shall be applied to a minimum thickness of one inch (1").
4. The geopolymer liner system shall be GEOKRETE, manufactured by Quadex, LLC, or approved equal.

C. RESTORATION AND CORROSION BARRIER COMPOSITE LINER

This system is a two-layer "composite" liner system as described below:

1. High-strength Restoration Mortar: The first layer the composite liner system shall be Mainstay ML-72, manufactured by Madewell Products Corporation, or approved equal. This is a high-strength restoration mortar which shall be applied to form a structural monolithic liner covering all interior surfaces and shall have the following minimum requirements:
- a. Compressive Strength (ASTM C109): 10,000 psi, 28 days
 - b. Flexural Strength (ASTM C293): 1,400 psi, 28 days
 - c. Tensile Strength (ASTM C496): 800 psi, 28 days

- d. Shrinkage (ASTM C596): 0.02% at 28 days
 - e. Bond Strength (ASTM C882): 2,000 psi, 28 days
 - f. Minimum thickness shall be one-half inch (0.5") or the minimum thickness required by the manufacturer, whichever is greater.
2. Epoxy Corrosion Barrier: The second layer of the composite liner system shall be Mainstay DS-5, manufactured by Madewell Products Corporation, or approved equal. This is a 100% solids epoxy corrosion barrier coating which shall be applied over the completed high-strength restoration mortar while the mortar is still in its uncured state (soft). The corrosion barrier shall be spray applied or spin cast. The epoxy liner material shall have the following minimum requirements:
 - a. Hardness, Shore D (ASTM D2240): 85 (+/- 2)
 - b. Adhesion (ASTM D4541), Concrete: Substrate Failure
 - c. Abrasion: ASTM D 4060 – Requirement: No more than 180 mg loss after 1,000 cycles
 - d. Corrosion Resistance: Suitable for environments with a PH of 0.5 or higher
 - e. Minimum thickness of the epoxy liner shall be 125 mils, dry film thickness.
 3. The composite liner system shall be MAINSTAY, manufactured by Madewell Products Corporation, or approved equal.

PART 3 EXECUTION

3.1 INITIAL INSPECTION

- A. Applicator shall take appropriate action to comply with all local, state, and federal regulations including those set forth by OSHA, EPA, the Owner and any other applicable authorities.
- B. Prior to conducting any work, an initial inspection of the structure shall be performed to determine need for protection against hazardous gases or oxygen depleted atmosphere and the need for flow control or flow diversion.
- C. If required, submit a plan for flow control or bypass to the engineer for approval prior to conducting the work.
- D. New Portland cement structures shall have endured a minimum of 28 days since manufacture prior to commencing installation of the liner system.

3.2 SURFACE PREPARATION

- A. The surface preparation program will include checking the atmosphere for hydrogen sulfide, methane, low oxygen, or other gases, approved flow control equipment, and surface preparation equipment.
- B. Surface preparation for standard manhole structures shall be in accordance with the manufacturer's recommendations, and may include high pressure water cleaning and shall provide a surface compatible for installation of the liner system.
- C. Surface preparation and methods for other structures shall be in accordance with the manufacturer's recommendations, and may include high pressure water cleaning, hydro blasting, abrasive blasting, grinding, or detergent water cleaning, and shall be suited to provide a surface compatible for installation of the liner system.
- D. The surface preparation method shall produce a cleaned, abraded and sound surface with no evidence of laitance, loose concrete, loose brick, loose mortar, contaminants or debris, and shall display a surface profile suitable for application of the liner system in accordance with the manufacturer's recommendations.
- E. After completion of surface preparation, inspecting for:
 1. Leaks
 2. Cracks
 3. Holes
 4. Exposed Rebar

5. Ring and Cover Condition
 6. Invert Condition
 7. Inlet and Outlet Pipe Condition
- F. After the defects in the structure are identified, repair all leaks and severe cracks with products and materials recommended and approved by the liner system manufacturer.
- G. Upon completion of leak and crack repair, the surface shall be primed in accordance with the manufacturer's recommendations.

3.3 MATERIAL INSTALLATION

- A. Application procedures shall conform to recommendations of the manufacturer, including materials handling, mixing, environmental controls during application, safety and spray equipment.
- B. Spray equipment shall be specifically designed to accurately ratio and apply the liner system.
- C. Application of liner system shall be in strict accordance with manufacturer's recommendation. Final installation minimum total thickness shall be as specified in subpart 2.3. A permanent identification and date of work performed shall be affixed to the structure in a readily visible location.
- D. A final written report shall be provided to the engineer detailing the location, date of work and description of the work.

3.4 TESTING

- A. For the Stress Skin Panel Liner and the Composite Liner systems, the following tests will be required for each layer of epoxy lining material:
 1. Wet Film Thickness Gage: During application a wet film thickness gage, meeting ASTM D4414 – Standard Practice for Measurement of Wet Film Thickness of Organic Coatings by Notched Gages, shall be used to ensure a monolithic coating and uniform thickness during application.
 2. Adhesion Test: Testing shall be conducted in accordance with ASTM D7234-05 at a rate of one test for every 10 structures with a minimum of one test per project.
- B. A Vacuum Test in accordance with Section 33 01 30.13 shall be performed on each lined structure immediately following the elapsed cure time of the final layer of product or material application as recommended by the liner system manufacturer.

3.5 FINAL INSPECTION

- A. Final liner system shall be completely free of pinholes or voids. Liner thickness shall be the minimum value as specified in subpart 2.3.
- B. Visual inspection shall be made by the Engineer. Any deficiencies in the finished liner system shall be marked and repaired according to the procedures set forth by the manufacturer.

END OF SECTION 33 39 16

Section 12
Geotechnical Report



**Colonial Court Lift Station – Tammany Utilities
Covington, Louisiana**

July 27, 2017
Terracon Project No. EH165195

Prepared for:
Buchart-Horn, Inc.
Baton Rouge, Louisiana

Prepared by:
Terracon Consultants, Inc.
Baton Rouge, Louisiana

terracon.com

The Terracon logo, featuring the word "Terracon" in a white, bold, sans-serif font on a dark red background.

Environmental



Facilities



Geotechnical



Materials



July 27, 2017

Buchart-Horn, Inc.
18163 E. Petroleum Drive, Suite A
Baton Rouge, LA 70809

Attn: Mr. Mira Para
P: 225-372-7157
E: MPara@bucharthorn.com

Re: Colonial Court Lift Station – Tammany Utilities
Covington, Louisiana
Terracon Project Number: EH165195

Dear Mr. Para:

We have completed the geotechnical engineering services for the above-referenced project. This work was performed in accordance with our proposal number PEH165195 dated May 25, 2016.

This report presents findings of the subsurface exploration and provides geotechnical recommendations concerning design and construction of the proposed lift station.

We should continue to collaborate with you as you finalize the designs. We should also review the pertinent aspects of the plans and specifications and provide construction materials and engineering testing services when the project moves into construction.

Sincerely,
Terracon Consultants, Inc.

Sunil Malla, P.E.
Senior Engineer
Geotechnical Services

Stephen E. Greaber, P.E.
Principal

Enclosure



Terracon Consultants, Inc. 2822 O'Neal Lane Building B Baton Rouge, Louisiana 70816
P [225] 344 6052 F [225] 344 6346 terracon.com

Environmental



Facilities



Geotechnical



Materials

TABLE OF CONTENTS

PROJECT DESCRIPTION

SITE CONDITIONS

SUBSURFACE CONDITIONS

EXPLORATION AND TESTING PROCEDURES

SITE CLASSIFICATION FOR SEISMIC DESIGN

GEOTECHNICAL OVERVIEW

LIFT STATION DESIGN CONSIDERATIONS

PROJECT CONSIDERATIONS

APPENDIX A – EXPLORATION AND LABORATORY RESULTS

Exhibit A-1	Site Location
Exhibit A-2	Exploration Plan
Exhibit A-3	Boring Log

APPENDIX B – SUPPORTING DOCUMENTS

Exhibit B-1	Explanation of Boring Log Information
Exhibit B-2	Unified Soil Classification System

PROJECT DESCRIPTION

The project information for developing the geotechnical recommendations are given below. This information was provided by Buchart Horn, Inc.

ITEM	DESCRIPTION
Project Location	The project site is near the southwest corner of the intersection of Colonial Court and Hickory Street in Covington, St. Tammany Parish, Louisiana. Approximate Coordinates: 30.41608, -90.07715
Proposed Structure	A lift station with an outside diameter of 11 feet is planned to be installed at a depth of 22 feet with the pump station invert at approximately 14 feet below existing ground surface.
Below grade construction	An approximate maximum 22-foot deep excavation will be required to install the lift station and bedding materials.

SITE CONDITIONS

The following description of site conditions is derived from our site visit in association with the field exploration and our review of local, publicly available geologic and topographic maps.

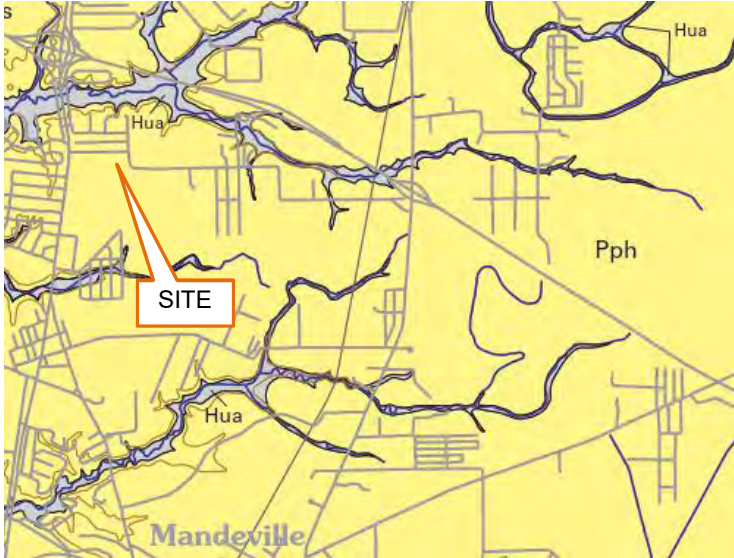
ITEM	DESCRIPTION
Location	At the south-west corner of the intersection of Colonial Court & Hickory Street in Covington, Louisiana.
Existing improvements	Undeveloped land.
Current ground cover	Grass and trees.
Existing topography	The proposed lift station site is relatively flat at approximate Elevation +17 feet (WGS84).
Geology	<p>The property is located within an area of the Hammond Alloformation (Pph) belonging to Prairie Terrace. These Pleistocene Age deposits of middle to late Wisconsin Coastal Plain streams include flood-plain deposits of the late Pleistocene Mississippi River, exposed in the eastern valley wall of the modern Mississippi River alluvial valley. The unit is blanketed by Peoria Loess. The deposits typically consist of an upper very silty clay or silt overlying medium stiff to very stiff tan and light gray silty clays and clays with silt and sand layering. The soils within the Prairie Terrace typically provide good foundation support for relatively light to moderately loaded structures, are overconsolidated, and normally only marginally compressible. In some areas that are very dry and desiccated, the potential for expansive properties exists, but these conditions are not typical of the Prairie Terrace deposits.</p>  <p>Ponchatoula 30 x 60 Minute Geological Quadrangle (2003)</p>

SUBSURFACE CONDITIONS

The following table provides a summary of the generalized soil conditions at the site.

Stratum	Typical Stratum Base (feet)	Material Description	Consistency/Density
Surface	0.58	Topsoil	N/A
1	17	Lean Clay (CL)	Stiff
2 ¹	40	Fat Clay (CH)	Stiff

1. The boring was terminated at 40 feet depth.

Conditions encountered at the boring location are indicated on the boring log. Stratification boundaries on the boring log represent the approximate location of changes in soil types; in situ, the transition between materials may be gradual. Further details of the boring can be found on the boring log in Appendix A of this report.

Groundwater Conditions

Specific observations of groundwater level as recorded for the boring are noted on the boring log in Appendix A, and are summarized below.

BORING NUMBER	DEPTH TO GROUNDWATER WHILE DRILLING, FEET	DEPTH TO GROUNDWATER AFTER ABOUT 15 MINUTES, FEET	DEPTH TO GROUND WATER IN THE PIEZOMETER AFTER ABOUT 2 WEEKS, FEET
B-01	25	24.5	11.6

Groundwater observed at the site at the time of drilling is not necessarily stable ground water at the site. Due to the low permeability of the soils encountered in the borings, a relatively long period may be necessary for the groundwater level to develop and stabilize in a borehole in these materials. A temporary piezometer to a depth of 27 feet, with a 5-foot long screen, sealed from the influence of surface water was installed in the borehole. The top of the screen was set at 22 feet depth, surrounded with sand and then sealed with a bentonite pellets. Water measurement, performed approximately two weeks after piezometer installation, indicated groundwater at a depth of 11.6 feet below the ground surface.

Groundwater level fluctuations occur due to seasonal variations in the amount of rainfall, runoff, river or creek levels, and other factors that are not evident at the time of drilling. Therefore, the groundwater levels that may prevail during construction or at other times in the life of the structure may be higher or lower than the levels observed during drilling and two weeks after drilling as indicated on the boring log. The possibility of groundwater level fluctuations should be considered when developing the design and construction plans for this project.

EXPLORATION AND TESTING PROCEDURES

Field Exploration

Our field exploration work included the drilling and sampling of exploratory soil boring consistent with the following schedule.

NUMBER OF LOCATIONS	TYPE OF EXPLORATION	EXPLORATION DEPTH (FEET)	LOCATION
1	Boring	40	Lift station vicinity
1	Piezometer	27	Lift station vicinity

The locations of field exploration points were established based on the site location map provided by Buchart Horn, Inc. A hand-held GPS unit was used by Terracon's exploration team to establish boring location referenced to known points in the field. The accuracy of the exploration points is usually within 10 to 20 feet of the noted location. The ground surface elevation was estimated from the Google Earth™ imagery and the accuracy of the ground surface at each point is probably about 2 feet. A survey of the boring location should be performed if a more precise elevation is required.

Soil Boring: We advanced the soil boring with a track-mounted drill rig using continuous flight augers (solid stem) to a depth of approximately 25 feet. Rotary wash drilling was used below 25 feet to the boring termination depth. We primarily obtained thin-walled tube samples to secure relatively undisturbed samples of cohesive and semi-cohesive materials. Shelby tube samples were obtained by hydraulically pushing a seamless steel tube with a sharpened cutting edge into the boring to obtain a relatively undisturbed sample of cohesive soil. We reported the sampling depths, penetration distances, and the standard penetration resistance values on the boring log. In the field, we placed the samples into containers, seal them, and return them to the laboratory for observation, testing and classification.

Our exploration team prepared field boring log as part of the drilling operations. The field log includes visual classifications of the materials encountered during drilling and our interpretation of the subsurface conditions between samples. Final boring log was prepared from the field log. The final boring log represents the engineer's interpretation of the field log and include modifications based on observations and tests of the samples in the laboratory.

Temporary Piezometer: A temporary piezometer was installed on June 27, 2017 after finishing the soil boring. The 2-inch diameter piezometer was constructed of polyvinyl chloride (PVC) casings installed near boring B-01 to a depth of 27 feet and included a 5-foot long screen at the bottom. When drilling reached the drilling depth, drilling fluid was circulated, drilling rods were retrieved from the borehole, and the screen and casings were inserted. The PVC screen and casings

were connected by threaded connections with “O” rings. The annular space around the screen was filled with a sand pack followed by sealing the top of the sand pack with bentonite at a depth of 22 feet. The remaining annular space was grouted to ground surface using a cement bentonite grout. The casing was hung in tension during grouting operation to allow for a plumb installation. After installation, the piezometer was completed with 2-inch diameter PVC riser and covered with a PVC cap.

Groundwater Observations: During the soil boring advancement and sampling operation, observations for free groundwater were made. Information regarding water level observations is recorded in the “groundwater” column on the soil boring log. Other information regarding water level observations has been noted under “Groundwater Level Data” at the bottom of each log. The ground water level was also measured in the temporary piezometer approximately two weeks after the soil boring was drilled.

Boring/Piezometer Abandonment: The soil boring was backfilled with cement bentonite grout after completion of drilling. The piezometer was also sealed with cement bentonite grout after measuring two-week ground water level.

Laboratory Testing

The project engineer reviewed the field data and assigned various laboratory tests to better understand the engineering properties of the various soil and rock strata as necessary for this project. Procedural standards noted below are for reference to methodology in general. In some cases, variations to methods are applied because of local practice or professional judgment. Standards noted below include reference to other, related standards. Such references are not necessarily applicable to describe the specific test performed.

- ASTM D2216-10 Standard Test Methods for Laboratory Determination of Water (Moisture) Content of Soil and Rock by Mass
- ASTM D4318-10e1 Standard Test Methods for Liquid Limit, Plastic Limit, and Plasticity Index of Soils
- ASTM D2166/D2166M-13 Standard Test Method for Unconfined Compressive Strength of Cohesive Soil

The laboratory testing program may often include examination of soil samples by an engineer. Based on the material’s texture and plasticity, we describe and classify the soil samples in accordance with the *Unified Soil Classification System*.

SITE CLASSIFICATION FOR SEISMIC DESIGN

Design of buildings and other structures subject to earthquake ground motions requires classification of the upper 100 feet of the site profile in accordance with Chapter 20 of ASCE 7. The Site Class types are listed below and are basically defined by an average value of either shear wave velocity, standard penetration resistance, or undrained shear strength.

- n A. Hard Rock
- n B. Rock
- n C. Very dense soil and soft rock
- n D. Stiff soil
- n E. Soft clay soil
- n F. Soils vulnerable to potential failure or collapse under seismic loading

Based on the results of our site characterization program, we conclude that Site Class D is appropriate for the subject site. Note that the scope of services did not include site profile determination to a depth of 100 feet. Explorations for this project extended to a maximum depth of 40 feet. Based on our knowledge of the geologic formation, the assumed site classification is considered reasonable. Additional exploration to deeper depths could be performed to confirm the conditions below the current depth of exploration. Alternatively, a geophysical exploration could be utilized to define the seismic site class.

GEOTECHNICAL OVERVIEW

The surficial soils at the site consist of stiff lean clay with silt seams extending to a depth of approximately 17 feet underlain by stiff fat clay extending to the boring termination depth of 40 feet. The following table provides soil parameters for the design of the excavation shoring system by others at the site.

APPROXIMATE DEPTH BELOW THE EXISTING GRADE (FT)	SOIL DESCRIPTION	MOISTURE CONTENT (%)	MOIST UNIT WEIGHT (pcf)	UNDRAINED SHEAR STRENGTH (psf)
17	Lean Clay	20 to 28	127	1,250
40	Fat Clay	34 to 48	115	1,400

Typically, the contractor selects the construction method. If either driven steel sheet piles or pre-engineered braced shoring box systems are selected, they should be designed with adequate bracing and bending resistance. Ground water observation after two weeks in the piezometer indicated the ground water at a depth of approximately 11 feet. The presence of obvious high permeability strata was not encountered to the termination depth of the exploration at 40 feet, and the soils at the site are considered relatively stiff. The **Lift Station Recommendations** section provides additional general recommendations pertaining to design and construction of the proposed lift station.

A primary concern during the excavation for the lift station is basal and/or hydrostatic heave of clay soils at the bottom of the excavation anticipated at a depth of 22 feet. Based on the results of the exploration, we anticipate that the planned excavation might be performed entirely within stiff lean and fat clay. An excavation to 22 feet would be expected to encounter some ground water seepage; however, the seepage rate should be relatively low considering the principally fat clay soil conditions. Seepage water within the excavation should be controllable with conventional sump pumps. Considering the thickness of clay below the bottom of excavation, an appropriately shored excavation appears to be feasible, if proper dewatering of the excavation is maintained and the side walls are supported to prevent collapse.

The contractor should be made aware that they are responsible for the analyses and selection of an excavation sloping, shoring, and dewatering method that will allow for the work to be completed in a safe and efficient manner consistent with the noted soil conditions described herein and the requirements of the plans and specifications. The contractor should provide a submittal to the engineer prior to start of construction that describes their planned installation procedures including their shoring design and dewatering plans.

The contractor should be advised that all excavations must be made and kept in compliance with the U.S. Department of Labor, Occupational Safety and Health Administration (OSHA) regulations. These regulations require that excavations greater than 4 feet in depth be sloped, benched, sheeted, or braced to protect employees working in the excavation against the risk of cave-in. These regulations are strictly enforced and if they are not followed, the owner, contractor, and/or earthwork and utility subcontractor could be liable and subject to substantial penalties. The contractor should design and select an appropriate shoring, dewatering and installation method that provides for the planned installation in accordance with the plans and specifications, is protective of adjacent structures, and anticipates soil and ground water conditions expected at the site. Construction site safety is the sole responsibility of the contractor who controls the means, methods and sequencing of construction operations. Under no circumstances shall the information provided herein be interpreted to mean that Terracon is assuming any responsibility for construction site safety or the contractor's activities, including design of shoring or dewatering systems; such responsibility shall neither be implied nor inferred.

LIFT STATION DESIGN CONSIDERATIONS

The project will require the construction of a lift station below natural grade. The primary geotechnical considerations affecting the lift station are excavation stability and resistance of the lift station to hydrostatic uplift.

The excavation for the lift station should be planned to a depth to incorporate at least a foot of bedding material below the bottom of the foundation slab. The bedding material should be a crushed #57 limestone aggregate.

Design Parameters

PARAMETER	SLAB FOUNDATION
Maximum net allowable bearing pressure ¹	2,000 psf
Required bearing stratum ²	Minimum 1 foot of crushed #57 limestone aggregate. Bearing stratum should be verified by Terracon.
Ultimate coefficient of sliding friction ³	0.32
Ultimate passive pressure ³	200 pcf, equivalent fluid density
Estimated settlement ⁴	< 1 inch
Modulus of subgrade reaction ⁵	150 pounds per square inch per inch (psi/in) for point loading conditions

1. The maximum net allowable bearing pressure is the pressure in excess of the minimum surrounding overburden pressure at the foundation base elevation. An appropriate factor of safety has been applied.
2. Unsuitable fat clay and soft soils should be undercut, and replaced with #57 limestone aggregate.
3. Passive resistance in the upper 3 feet of the soil profile should be neglected. Depending on the magnitude of uplift forces, the base friction should be reduced or neglected. The foundation must be able to displace laterally on the order of ¼ to ½ inch in order to develop the passive resistance. Apply a factor of safety of at least 2 to these values when designing for lateral force resistance.
4. Settlement as a result of the structural loads and reorientation of the limestone gravel.
5. Based on a minimum 1 foot of crushed #57 limestone aggregate.

Uplift of the lift station foundation slab from hydrostatic forces is perhaps the governing factor in design of the proposed structure. The ground water observation after two weeks, in the piezometer with top of screen at 22 feet depth, indicated the water level to be at a depth of 11.6 feet below the existing ground surface. We recommend that the designer should evaluate the lift station with ground water at the ground surface.

Bedding Material

The bedding material should meet the following material property requirements:

FILL TYPE ¹	USCS CLASSIFICATION	ACCEPTABLE LOCATION FOR PLACEMENT
#57 Limestone	GP	Bedding layer below slab foundation. Nonwoven geotextile fabric should be used between the gravel layer and the foundation subgrade.

1. Controlled, compacted fill should consist of approved materials that are free of organic matter and debris. A sample of each material type should be submitted to the geotechnical engineer for evaluation.

Compaction Requirements

The bedding material should meet the following compaction requirements:

ITEM	DESCRIPTION
Lift Thickness	4 to 6 inches in loose thickness when hand-guided equipment (i.e. jumping jack or plate compactor) is used
Compaction Requirements ¹	Minimum 95% of the standard Proctor maximum dry density (ASTM D 698)

1. The compaction should be measured for each lift during placement. Should the results of the in-place density tests indicate the specified compaction limits have not been met, the area represented by the test should be reworked and retested as required until the compaction requirements are achieved.
2. Compaction testing of the bedding stone layer is not required. However, it should be documented that the stone was compacted/oriented making a minimum of 3 passes in perpendicular directions with a vibratory plate compactor.

PROJECT CONSIDERATIONS

Our work is conducted with the understanding of the project as noted in **Project Understanding**. Verification of any stated assumptions and revision of our understanding to reflect actual conditions is important to our work, and the design team should collaborate with Terracon to confirm this understanding.

The design team should collaborate with Terracon to prepare the final design plans and specifications. This facilitates the incorporation of our opinions related to implementation of our geotechnical recommendations.

Our analysis and opinions are based upon our understanding of the geotechnical conditions in the area, the data obtained from the site exploration performed and from our understanding of the project. Variations will occur between exploration point locations, across the site, or due to the modifying effects of construction or weather. The nature and extent of such variations may not become evident until during or after construction. So, Terracon should be retained to provide observation and testing services during grading, excavation, and other earth-related construction phases of the project. If variations appear, we can provide further evaluation and supplemental recommendations. If variations are noted in the absence of our observation and testing services on-site, we should be immediately notified so that we can provide evaluation and supplemental recommendations.

Our scope of services does not include either specifically or by implication any environmental or biological (e.g., mold, fungi, bacteria) assessment of the site or identification or prevention of pollutants, hazardous materials or conditions. If the owner is concerned about the potential for such contamination or pollution, other studies should be undertaken.

Our services and any correspondence are intended for the exclusive use of Buchart-Horn, Inc for specific application to the project discussed and are accomplished in accordance with generally accepted geotechnical engineering practices. No warranties, either express or implied, are intended or made.

Site characteristics as provided are for design purposes and not to estimate excavation cost. Any use of our report in that regard is done at the sole risk of the excavating cost estimator as there may be variations on the site that are not apparent in the data that could significantly impact excavation cost. Any parties charged with estimating excavation costs should seek their own site characterization for that specific purposes to obtain the specific level of detail necessary for costing. Site safety, and other cost estimating including, excavation support, and dewatering requirements are the responsibility of others. In the event that changes in the nature, design, or location of the project are planned, our conclusions and recommendations shall not be considered valid unless we review the changes and either verify or modify our conclusions in writing.

APPENDIX A
EXPLORATION AND LABORATORY RESULTS

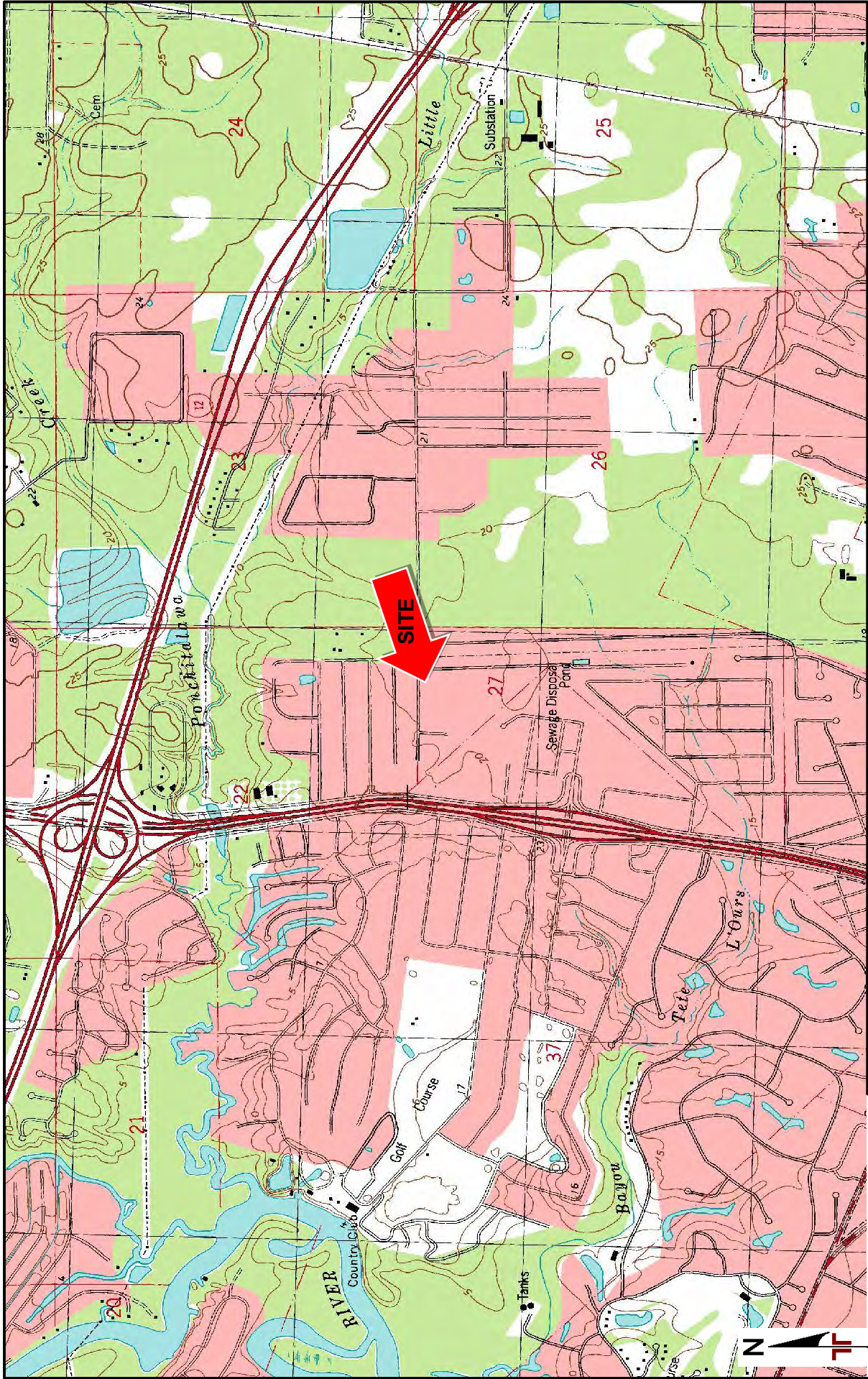

TOPOGRAPHIC MAP IMAGE COURTESY OF THE U.S. GEOLOGICAL SURVEY. QUADRANGLES INCLUDE: COVINGTON, LA (1/1/1998).

DIAGRAM IS FOR GENERAL LOCATION ONLY, AND IS NOT INTENDED FOR CONSTRUCTION PURPOSES

Project Manager:	SM
Drawn by:	MIS
Checked by:	SM
Approved by:	SEG

Project No:	EH165195
Scale:	1"=2,000'
File Name:	A-1
Date:	7/12/2017

Terracon
 2822 Oneal Ln Bldg B
 Baton Rouge, LA 70816-3127

SITE LOCATION

Colonial Court Lift Station - Tammany Utilities
 Colonial Court & Hickory Street
 Covington, LA

Exhibit **A-1**



Exhibit
A-2

EXPLORATION PLAN
Colonial Court Lift Station - Tammany Utilities
Colonial Court & Hickory Street
Covington, LA

Terracon
2822 Oneal Ln Bldg B
Baton Rouge, LA 70816-3127

Project No: EH165195
Scale: NTS
File Name: A-2
Date: 7/12/2017

Project Manager: SM
Drawn by: MIS
Checked by: SM
Approved by: SEG

AERIAL PHOTOGRAPHY PROVIDED BY
GOOGLE EARTH

DIAGRAM IS FOR GENERAL LOCATION ONLY,
AND IS NOT INTENDED FOR CONSTRUCTION
PURPOSES

BORING LOG NO. B-01

PROJECT: Colonial Court Lift Station - Tammany Utilities

CLIENT: Bucharth-Horn, Inc.
18163 E. Petroleum Drive, Suite A

SITE: Covington, LA

Baton Rouge, LA 70809

GRAPHIC LOG	LOCATION See Exhibit A-2 Latitude: 30.41608° Longitude: -90.07715°	DEPTH (Ft.)	WATER LEVEL OBSERVATIONS	SAMPLE TYPE	FIELD TEST RESULTS	STRENGTH TEST			WATER CONTENT (%)	DRY UNIT WEIGHT (pcf)	ATTERBERG LIMITS
						TEST TYPE	COMPRESSIVE STRENGTH (tsf)	STRAIN (%)			LL-PL-PI
		0.6									
7" TOPSOIL											
LEAN CLAY (CL), tan and gray, stiff, with silt					3.75 (HP)						
					2.00 (HP)	UC	1.25	12.5	20	108	41-13-28
		5			2.25 (HP)						
					3.00 (HP)						
		8.0			3.25 (HP)	UC	1.70	7	26	99	50-17-33
FAT CLAY (CH), gray, stiff, with trace silt, with trace ferrous nodules											
					3.00 (HP)						
		14.0			2.25 (HP)				28		42-25-17
LEAN CLAY (CL), tan, stiff											
					4.00 (HP)	UC	1.54	3.7	38	87	60-25-35
FAT CLAY (CH), brown, stiff											
		18.0									
FAT CLAY (CH), tan and gray, stiff					3.50 (HP)	UC	1.33	2.7	46	76	
		23.0									
		25	▽▽								

Stratification lines are approximate. In-situ, the transition may be gradual.

Advancement Method:
0'-25' Continuous flight auger, 25'-40' Rotary wash

Abandonment Method:
Borings backfilled with cement-bentonite grout upon completion.

See Appendix B for explanation of symbols and abbreviations.
Elevation based on Google Earth

Notes:

WATER LEVEL OBSERVATIONS

- ▽ Groundwater first encountered
- ▽ After 15 minutes



Boring Started: 6/27/2017

Boring Completed: 6/27/2017

Drill Rig: Triangle

Driller: B. Chandler

Project No.: EH165195

Exhibit: A-3

THIS BORING LOG IS NOT VALID IF SEPARATED FROM ORIGINAL REPORT. GEO SMART LOG-NO WELL - EH165195.GPJ TERRACON_DATATEMPLATE.GDT 7/13/17

BORING LOG NO. B-01

PROJECT: Colonial Court Lift Station - Tammany Utilities

CLIENT: Bucharth-Horn, Inc.
18163 E. Petroleum Drive, Suite A

SITE: Covington, LA

Baton Rouge, LA 70809

GRAPHIC LOG	LOCATION See Exhibit A-2 Latitude: 30.41608° Longitude: -90.07715°	DEPTH (Ft.)	WATER LEVEL OBSERVATIONS	SAMPLE TYPE	FIELD TEST RESULTS	STRENGTH TEST			WATER CONTENT (%)	DRY UNIT WEIGHT (pcf)	ATTERBERG LIMITS
						TEST TYPE	COMPRESSIVE STRENGTH (tsf)	STRAIN (%)			LL-PL-PI
DEPTH											
	FAT CLAY (CH) , tan and gray, stiff <i>(continued)</i>										
		28.0			3.25 (HP)	UC	1.47	3.3	34	86	
	FAT CLAY (CH) , gray, stiff										
		38.0			3.00 (HP)						
	FAT CLAY (CH) , brown and gray, stiff, with trace ferrous nodules				2.00 (HP)				48		
	Boring Terminated at 40 Feet	40.0									

Stratification lines are approximate. In-situ, the transition may be gradual.

Advancement Method:
0'-25' Continuous flight auger, 25'-40' Rotary wash

Abandonment Method:
Borings backfilled with cement-bentonite grout upon completion.

See Appendix B for explanation of symbols and abbreviations.
Elevation based on Google Earth

Notes:

WATER LEVEL OBSERVATIONS

- ▽ Groundwater first encountered
- ▽ After 15 minutes



Boring Started: 6/27/2017

Boring Completed: 6/27/2017

Drill Rig: Triangle

Driller: B. Chandler

Project No.: EH165195













Exhibit: A-3

THIS BORING LOG IS NOT VALID IF SEPARATED FROM ORIGINAL REPORT. GEO SMART LOG-NO WELL_EH165195.GPJ TERRACON_DATATEMPLATE.GDT 7/13/17

APPENDIX B
SUPPORTING DOCUMENTS

EXPLANATION OF BORING LOG INFORMATION

DESCRIPTION OF SYMBOLS AND ABBREVIATIONS

SAMPLING			WATER LEVEL OBSERVATIONS		Water Level Initially Encountered	FIELD TESTS	(HP)	Hand Penetrometer (tsf)	
	Auger	Split Spoon			Water Level After a Specified Period of Time		(T)	Torvane (tsf)	
					Water Level After a Specified Period of Time		(b/f)	Standard Penetration Test (blows per foot)	
	Shelby Tube	Macro Core			No Water Level Observed		(PID)	Photo-Ionization Detector (ppm)	
				Water levels indicated on the soil boring logs are the levels measured in the borehole at the times indicated. Water level variations will occur over time. In low permeability soils, accurate determination of water levels is not possible with short term water level observations.				(OVA)	Organic Vapor Analyzer (ppm)
	No Recovery	Rock Core							
									
	Ring Sampler	Ring Sampler							

DESCRIPTIVE SOIL CLASSIFICATION

Soil classification is based on the Unified Soil Classification System. Coarse Grained Soils have more than 50% of their dry weight retained on a #200 sieve; their principal descriptors are: boulders, cobbles, gravel or sand. Fine Grained Soils have less than 50% of their dry weight retained on a #200 sieve; they are principally described as clays if they are plastic, and silts if they are slightly plastic or non-plastic. Major constituents may be added as modifiers and minor constituents may be added according to the relative proportions based on grain size. In addition to gradation, coarse-grained soils are defined on the basis of their in-place relative density and fine-grained soils on the basis of their consistency.

LOCATION AND ELEVATION NOTES

Unless otherwise noted, Latitude and Longitude are approximately determined using a hand-held GPS device. The accuracy of such devices is variable. Surface elevation data annotated with +/- indicates that no actual topographical survey was conducted to confirm the surface elevation. Instead, the surface elevation was approximately determined from topographic maps of the area.

STRENGTH TERMS	RELATIVE DENSITY OF COARSE-GRAINED SOILS (More than 50% retained on No. 200 sieve.) Density determined by Standard Penetration Resistance		CONSISTENCY OF FINE-GRAINED SOILS (50% or more passing the No. 200 sieve.) Consistency determined by laboratory shear strength testing, field visual-manual procedures or standard penetration resistance		
	Descriptive Term (Density)	Std. Penetration Resistance (blows per foot)	Descriptive Term (Consistency)	Undrained Shear Strength (kips per square foot)	Std. Penetration Resistance (blows per foot)
	Very Loose	0 - 3	Very Soft	less than 0.25	0 - 1
	Loose	4 - 9	Soft	0.25 to 0.50	2 - 4
	Medium Dense	10 - 29	Medium-Stiff	0.50 to 1.00	5 - 7
	Dense	30 - 50	Stiff	1.00 to 2.00	8 - 14
	Very Dense	≥ 50	Very Stiff	2.00 to 4.00	15 - 30
		Hard	above 4.00	≥ 30	

RELATIVE PROPORTIONS OF SAND AND GRAVEL

Descriptive Term(s) of other constituents	Percent of Dry Weight
Trace	< 15
With	15 - 29
Modifier	> 30

GRAIN SIZE TERMINOLOGY

Descriptive Term(s) of other constituents	Percent of Dry Weight
Boulders	Over 12 in. (300 mm)
Cobbles	12 in. to 3 in. (300mm to 75mm)
Gravel	3 in. to #4 sieve (75mm to 4.75 mm)
Sand	#4 to #200 sieve (4.75mm to 0.075mm)
Silt or Clay	Passing #200 sieve (0.075mm)

RELATIVE PROPORTIONS OF FINES

Descriptive Term(s) of other constituents	Percent of Dry Weight
Trace	< 5
With	5 - 12
Modifier	≥ 12

PLASTICITY DESCRIPTION

Term	Plasticity Index
Non-plastic	0
Low	1 - 10
Medium	11 - 30
High	≥ 30



UNIFIED SOIL CLASSIFICATION SYSTEM

Criteria for Assigning Group Symbols and Group Names Using Laboratory Tests ^A				Soil Classification		
				Group Symbol	Group Name ^B	
Coarse Grained Soils: More than 50% retained on No. 200 sieve	Gravels: More than 50% of coarse fraction retained on No. 4 sieve	Clean Gravels: Less than 5% fines ^C	$Cu \geq 4$ and $1 \leq Cc \leq 3$ ^E	GW	Well-graded gravel ^F	
		Gravels with Fines: More than 12% fines ^C	Fines classify as ML or MH	GP	Poorly graded gravel ^F	
			Fines classify as CL or CH	GM	Silty gravel ^{F,G,H}	
		Sands: 50% or more of coarse fraction passes No. 4 sieve	Clean Sands: Less than 5% fines ^D	$Cu \geq 6$ and $1 \leq Cc \leq 3$ ^E	GC	Clayey gravel ^{F,G,H}
	Sands with Fines: More than 12% fines ^D		Fines classify as ML or MH	SW	Well-graded sand ^I	
			Fines classify as CL or CH	SP	Poorly graded sand ^I	
	Silts and Clays: Liquid limit less than 50		Inorganic:	$PI > 7$ and plots on or above "A" line ^J	SM	Silty sand ^{G,H,I}
		Organic:	$PI < 4$ or plots below "A" line ^J	SC	Clayey sand ^{G,H,I}	
Fine-Grained Soils: 50% or more passes the No. 200 sieve	Silts and Clays: Liquid limit 50 or more	Inorganic:	$PI > 7$ and plots on or above "A" line ^J	CL	Lean clay ^{K,L,M}	
		Organic:	Liquid limit - oven dried	< 0.75	ML	Silt ^{K,L,M}
			Liquid limit - not dried		OL	Organic clay ^{K,L,M,N}
		Silts and Clays: Liquid limit less than 50	Inorganic:	PI plots on or above "A" line	OH	Organic silt ^{K,L,M,O}
	Organic:		PI plots below "A" line	CH	Fat clay ^{K,L,M}	
			Liquid limit - oven dried	< 0.75	MH	Elastic Silt ^{K,L,M}
	Liquid limit - not dried		OH		Organic clay ^{K,L,M,P}	
	Highly organic soils: Primarily organic matter, dark in color, and organic odor				PT	Peat

^A Based on the material passing the 3-inch (75-mm) sieve

^B If field sample contained cobbles or boulders, or both, add "with cobbles or boulders, or both" to group name.

^C Gravels with 5 to 12% fines require dual symbols: GW-GM well-graded gravel with silt, GW-GC well-graded gravel with clay, GP-GM poorly graded gravel with silt, GP-GC poorly graded gravel with clay.

^D Sands with 5 to 12% fines require dual symbols: SW-SM well-graded sand with silt, SW-SC well-graded sand with clay, SP-SM poorly graded sand with silt, SP-SC poorly graded sand with clay

$$E \quad Cu = D_{60}/D_{10} \quad Cc = \frac{(D_{30})^2}{D_{10} \times D_{60}}$$

^F If soil contains $\geq 15\%$ sand, add "with sand" to group name.

^G If fines classify as CL-ML, use dual symbol GC-GM, or SC-SM.

^H If fines are organic, add "with organic fines" to group name.

^I If soil contains $\geq 15\%$ gravel, add "with gravel" to group name.

^J If Atterberg limits plot in shaded area, soil is a CL-ML, silty clay.

^K If soil contains 15 to 29% plus No. 200, add "with sand" or "with gravel," whichever is predominant.

^L If soil contains $\geq 30\%$ plus No. 200 predominantly sand, add "sandy" to group name.

^M If soil contains $\geq 30\%$ plus No. 200, predominantly gravel, add "gravelly" to group name.

^N $PI \geq 4$ and plots on or above "A" line.

^O $PI < 4$ or plots below "A" line.

^P PI plots on or above "A" line.

^Q PI plots below "A" line.

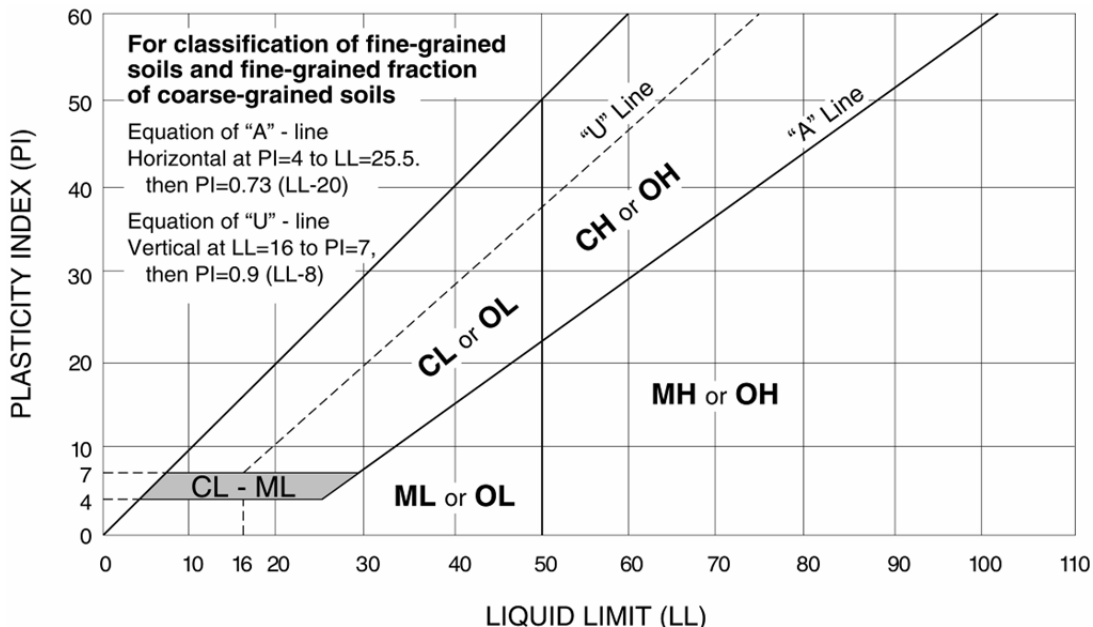



ST. TAMMANY PARISH

PATRICIA P. BRISTER
PARISH PRESIDENT

July 3, 2018

Please find the following addendum to the below mentioned BID.

Addendum No.: 2
Bid#: 622-10-18-31-2
Project Name: Colonial Court Lift Station Upgrade
Bid Due Date July 24, 2018

GENERAL INFORMATION:

- 1. Please note that the Bid Opening has been pushed to Tuesday, July 24, 2018. Time and location remains the same.**
- 2. Last Day for Inquiries and requests for approved equals is Friday, July 13, 2018 no later than 2:00PM.**
- 3. All requests for approved equals must be submitted prior to the inquiry deadline. Particular attention must be given by Bidders requesting consideration for an approved equal to provide sufficient information for a determination to be made. Please refer to Section 8, General Conditions for St. Tammany Parish Government, Paragraph 13.04. Generally speaking, the information that must be provided is listed in Part 1 of the appropriate specification section and the criteria that must be met are listed in Part 2 of the appropriate specification section.**

<< End of Addendum # 2 >>



ST. TAMMANY PARISH

PATRICIA P. BRISTER
PARISH PRESIDENT

June 27, 2018

Please find the following addendum to the below mentioned BID.

Addendum No.: 1
Bid#: 622-10-18-31-2
Project Name: Colonial Court Lift Station Upgrade
Bid Due Date: July 12, 2018

GENERAL INFORMATION:

1. Please **DELETE** Plan Sheet G-101 from Section 11 Project Plans and replace with Plan Sheet G-101R (attached). The Index to Sheets has been revised.
2. Please **ADD** Plan Sheet C-100N (attached) to Section 11 Project Plans before Plan Sheet C-101R (attached). The extent of the demolition work required under this Contract is depicted.
3. Please **DELETE** Plan Sheet C-101 from Section 11 Project Plans and replace with Plan Sheet C-101R (attached). The addition of a fence, revisions to the gravity sewer callouts in plan and profile views, the addition of General Note 7, and the addition of the list of abbreviations are depicted.
4. Please **DELETE** Plan Sheet C-102 from Section 11 Project Plans and replace with Plan Sheet C-102R (attached). Slab penetration and pipe support details have been added.
5. Please **DELETE** Section 00 01 10 – Table of Contents from Section 10 Project Specifications in its entirety and replace with Section 00 01 10 – Table of Contents – Revised (attached). The Table of Contents has been revised.
6. Please **ADD** Section 09 96 00 – High Performance Coatings (attached) to Section 10 Project Specifications between the last page of Section 09 90 00 and the first page of Section 25 02 00.
7. Please **REPLACE** Section 33 31 13 – Sanitary Sewer Pipe in Section 10 Project Specifications in its entirety with Section 33 31 13 – Sanitary Sewer Pipe – Revised (attached).



ST. TAMMANY PARISH

PATRICIA P. BRISTER
PARISH PRESIDENT

QUESTIONS & ANSWERS:

Question #1: Plan Sheet C-101 - 12" Gravity Line between old and new Wet Wells: Site Plan calls for this to be R.C.P. while the New Lift Station Profile shows it to be PVC. Which is correct? If PVC is correct, what class PVC pipe (C-900, SDR-35, SDR-26, other) will be required?

Answer #1: The 12" gravity sewer between the old and new wet well shall be PVC (SDR-35). Please refer to Section 11 Project Plans, Plan Sheet C-101R (attached).

Question #2: Plan Sheet C-101 - Pump Suction Piping: New Lift Station Section shows the 90° bends for the suction lines to be 6" L.R. Shouldn't these be 6" x 4" L.R.?

Answer #2: No. The pump depicted on the plans is the basis of design referenced in the specifications, Model V4A-B-1 as manufactured by Gorman-Rupp. Model V4A-B-1 has a 4" discharge flange and a 6" suction flange. If the pump being provided by the contractor is the same pump as the basis of design, the 6" LR elbow is the appropriate fitting for the suction elbow. The contractor shall supply the appropriate size suction and discharge elbows based on the pump actually being provided.

Question #3: Plan Sheet C-101 - Pump Discharge Piping: Are the 6" x 4" Flg. 90° Bends on the pump discharge to be S.R. or L.R.?

Answer #3: Unless otherwise indicated, all 90° elbows shall be LR 90° elbows. Please refer to Section 11 Project Plans, Plan Sheet C-101R (attached).

Question #4: Plan Sheet C-101 - Pump Discharge Piping: The New Lift Station Plan and New Lift Station Section both call for (2) 6" DMJ between the discharge 90° bend and the check valve. What does "DMJ" stand for?

Answer #4: DMJ stands for Dismantling Joint. Please refer to Section 11 Project Plans, Plan Sheet C-101R (attached) and Section 10 Project Specifications, Section 33 31 13 – Revised (attached).



ST. TAMMANY PARISH

PATRICIA P. BRISTER
PARISH PRESIDENT

Question #5: Plan Sheet C-101 - New Wet Well: The New Lift Station Section shows a 9' Ø wet well with reinforcing steel being required between the wet well walls and the top and base slabs. This would indicate to us that you do not want the new wet well to be pre-cast, but poured in place. Further confirmation of this is the fact that most concrete pipe manufacturers who make 108" Ø precast concrete pipe only have a 10" wall while your drawings require a 12" wall. If it is your intention to require that the wet well walls be poured in place, would you accept an 8' x 8' square (64 S.F. of area) wet well in lieu of the 9' Ø (63.62 S.F. of area) wet well? Finding a forming system that provides a 9' I.D. and 11' O.D. will be very hard, if not impossible, to find.

Answer #5: No, a 9' diameter precast wet well with 8" wall thickness will be allowed provided the contractor submits structural and buoyancy calculations sealed by a Louisiana structural engineer. Yes, a cast-in-place 8' x 8' square wet well will be allowed provided the contractor submits structural and buoyancy calculations sealed by a Louisiana structural engineer.

Question #6: Plan Sheet C-101 - Top Slab Penetrations: Please provide a detail as to how you want the pipe penetrations through the top slab. Will a galvanized deck thimble with either the appropriate size Link-Seal type sealing elements or non-shrink grout be required?

Answer #6: Please refer to Section 11 Project Plans, Plan Sheet C-102R (attached) for penetration details.

Question #7: Plan Sheet C-101 - Fence: We noticed that there is no requirement for erecting a fence of any kind around the new Wet Well, Controls, etc. Will a new fence be required? The existing Lift Station does have a wooden fence. Does the existing fence remain or is it to be demolished?

Answer #7: The existing fence is to be demolished. Please refer to Section 11 Project Plans, Plan Sheet C-100N (attached). A new fence is now being included. Please refer to Section 11 Project Plans, Plan Sheet C-101R (attached). Refer to LADOTD Section 705.

Question #8: Plan Sheet C-101 - Demo at Existing Lift Station: To what extent is the existing lift station, pumps, piping, valves, controls, fence, electrical junction boxes, etc. to be demolished once the new Station is operable?

Answer #8: Please refer to Section 11 Project Plans, Plan Sheet C-100N (attached).



ST. TAMMANY PARISH

PATRICIA P. BRISTER
PARISH PRESIDENT

Question #9: Plan Sheet C-101 - Note #6: This note states that the Parish will clear the trees from the site for work prior to issuing a NTP for this project. Will that include any stumps that fall within the areas to be excavated under this contract?

Answer #9: No. The Parish will clear trees to be approximately flush with the ground but will not remove stumps. Stumps located within areas to be excavated under this contract will need to be removed by the Contractor.

Question #10: Plan Sheet C-101 - Pump Suction Piping: In the New Lift Station Section there is a note that says "6" SST Suction Line". What does "SST" stand for?

Answer #10: SST stands for stainless steel. Please refer to Section 11 Project Plans, Plan Sheet C-101R (attached) and Section 10, Project Specifications, Section 33 31 13 – Revised (attached).

Question #11: Plan Sheet C-101 - Pipe Supports: Will the supports for the suction and discharge piping need to be galvanized, stainless steel or painted?

Answer #11: Yes, above grade pipe supports shall be galvanized and painted. Please refer to Section 11 Project Plans, Plan Sheet C-102R (attached).

ATTACHMENTS:

1. Plan Sheet G-101R.pdf
2. Plan Sheet C-100N.pdf
3. Plan Sheet C-101R.pdf
4. Plan Sheet C-102R.pdf
5. Section 10 Project Specifications, Section 00 01 10 – Table of Contents – Revised.pdf
6. Section 10 Project Specifications, Section 09 96 00 – High Performance Coatings.pdf
7. Section 10 Project Specifications, Section 33 31 13 – Sanitary Sewer Pipe – Revised.pdf

<< End of Addendum # 1 >>

INDEX TO SHEETS

SHEET NO. DESCRIPTION

G-101R	TITLE SHEET
--------	-------------

CIVIL SHEETS

C-100N	DEMOLITION PLAN
C-101R	SITE PLAN
C-102R	CONCRETE SLAB DETAILS

ELECTRICAL SHEETS

E-101	ABBREVIATIONS, SYMBOLS, & BACKBOARD DETAIL
E-102	ONE LINE DIAGRAM & DUCTBANK DETAILS
E-103	ELECTRICAL DETAILS

ST. TAMMANY PARISH, LOUISIANA

COLONIAL COURT LIFT STATION UPGRADE

PROJECT NO.: TU16000193
BID NO.: 622-10-18-31-2

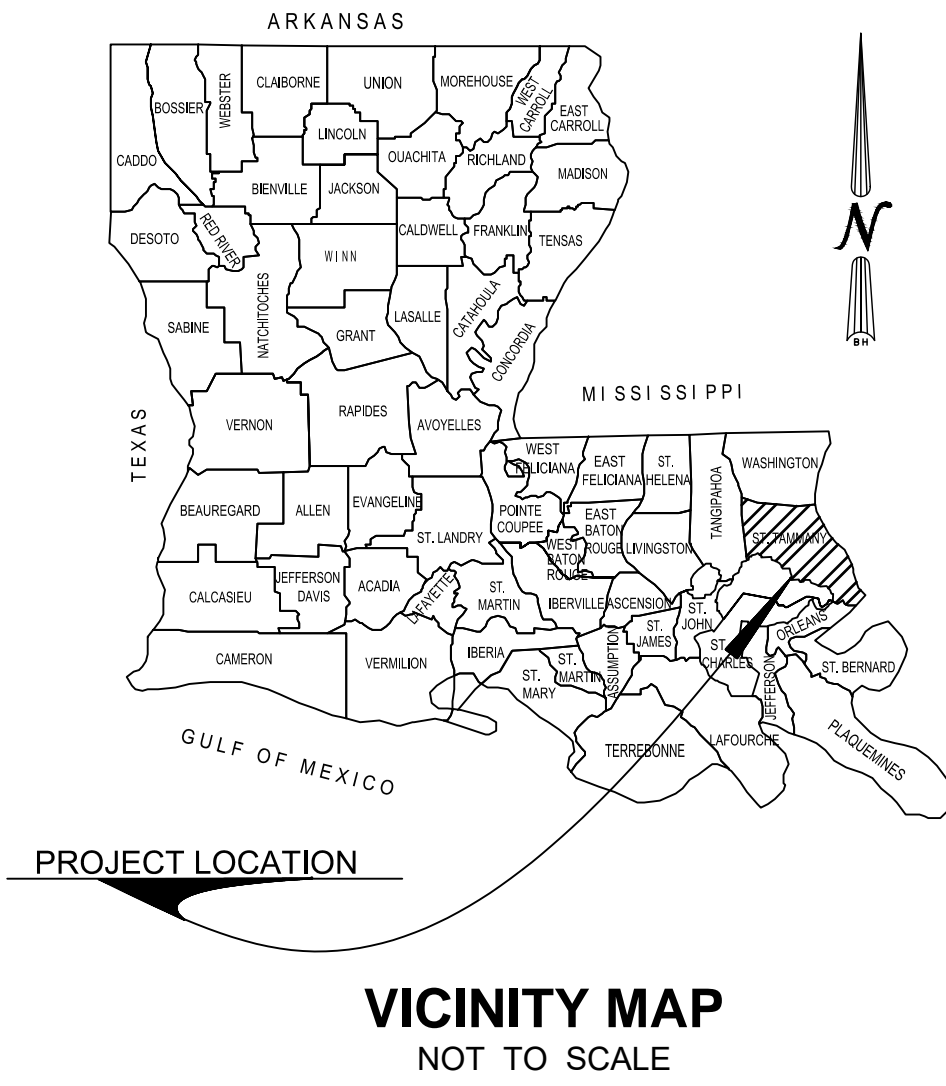

**COLONIAL COURT
 LIFT STATION UPGRADE
 ST. TAMMANY PARISH**

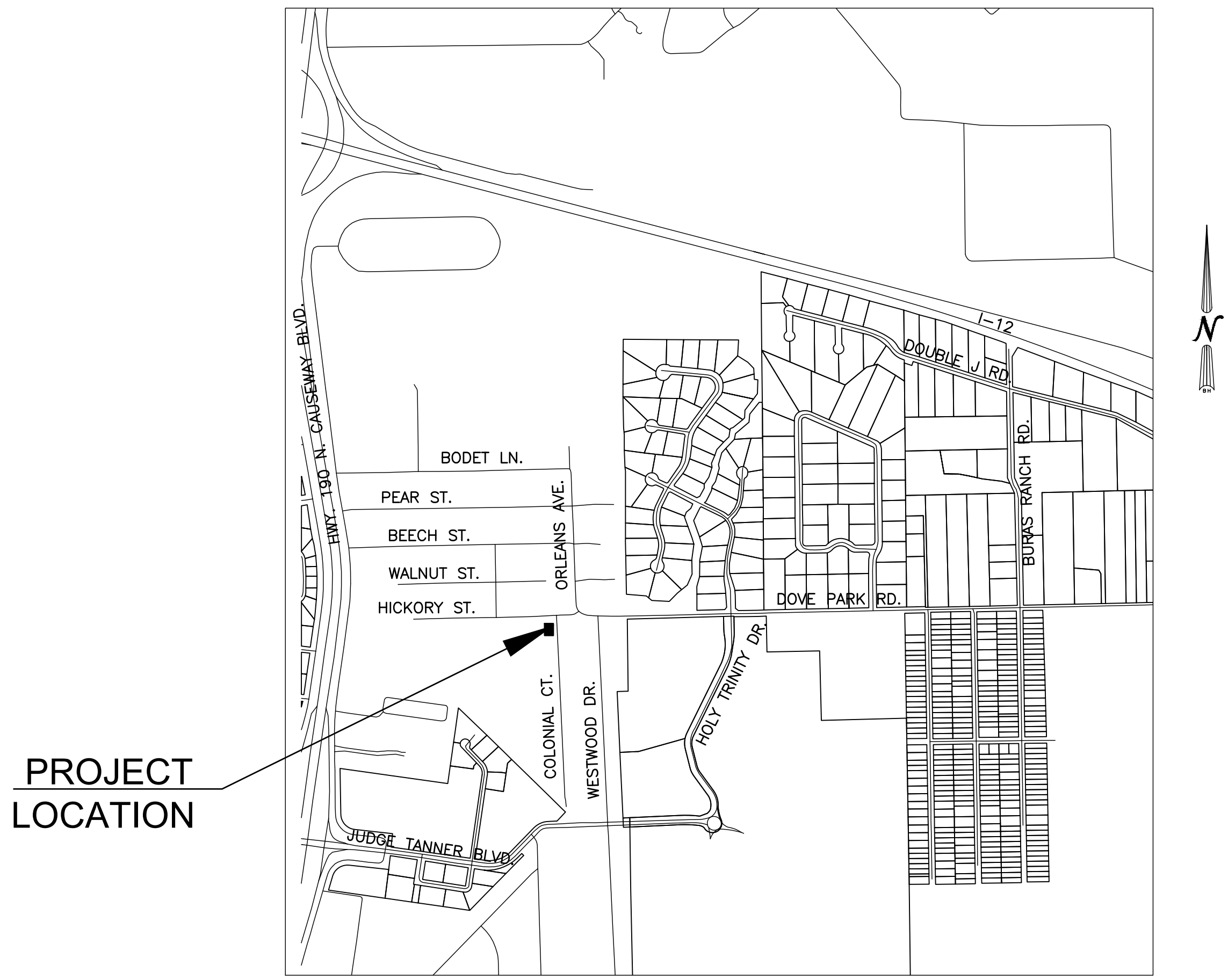

LOCATION MAP
SCALE: 1" = 1000'

PROJECT CLASSIFICATION:
 HEAVY CONSTRUCTION AND/OR MUNICIPAL & PUBLIC WORKS CONSTRUCTION

CONSTRUCTION TYPE:
 CLEARING & GRUBBING, GRADING, PIPE WORK STORM DRAIN, EQUIPMENT FOUNDATION,
 CONCRETE FLATWORK, ELECTRICAL, INSTRUMENTAL CONTROLS, PIPE WORK SEWER LINE & WASTE WATER PUMP STATION

ST. TAMMANY PARISH COUNCIL MEMBERS

- PATRICIA B. BRISTER – PARISH PRESIDENT
- MARTY DEAN (DISTRICT 1)
 - DAVID R. FITZGERALD (DISTRICT 2)
 - JAMES A. THOMPSON (DISTRICT 3)
 - MICHAEL LORINO, JR. (DISTRICT 4)
 - RYKERT O. TOLEDANO, JR (DISTRICT 5)
 - RICHARD E. TANNER (DISTRICT 6)
 - JACOB B. GROBY, III (DISTRICT 7)
 - CHRIS CANULETTE (DISTRICT 8)
 - E.L. BELLISARIO (DISTRICT 9)
 - MAUREEN O'BRIEN (DISTRICT 10)
 - STEVE STEFANCIK (DISTRICT 11)
 - JERRY BINDER (DISTRICT 12)
 - S. MICHELE BLANCHARD (DISTRICT 13)
 - THOMAS J. SMITH (DISTRICT 14)

PLANS PREPARED AND SUBMITTED BY:

MIRA K. PARA, P.E.
 BUCHART HORN, INC.
 PROJECT ENGINEER

Mira K. Para
 PROFESSIONAL ENGINEER License # 34990
 4/22/2018 DATE

APPROVED BY:

GREG GORDAN, DIRECTOR
 DEPT. OF ENVIRONMENTAL SERVICES, ST. TAMMANY PARISH

NO.	REVISION	DATE

PROJECT NO.:	77183-00
CAD FILE:	G-101R.DWG
ENGR./ARCH.:	MKP
DESIGN BY:	MKP
DRAWN BY:	DMB
CHECKED BY:	MKP
DATE:	04/26/2018

DRAWING INTENT IS TO INDICATE GENERAL ARRANGEMENT, DESIGN AND INTENT OF WORK AND IS PARTLY DIAGRAMMATIC. DRAWING SHALL NOT BE SCALED.
 © BUCHART HORN, INC.

TITLE SHEET

DRAWING NO.
G-101R

J:\PROJ\77183-00\CADD\Title Sheets\G-101R.TITLE SHEET.dwg 6/22/2018 8:55:18 AM

COLONIAL COURT
LIFT STATION UPGRADE
ST. TAMMANY PARISH

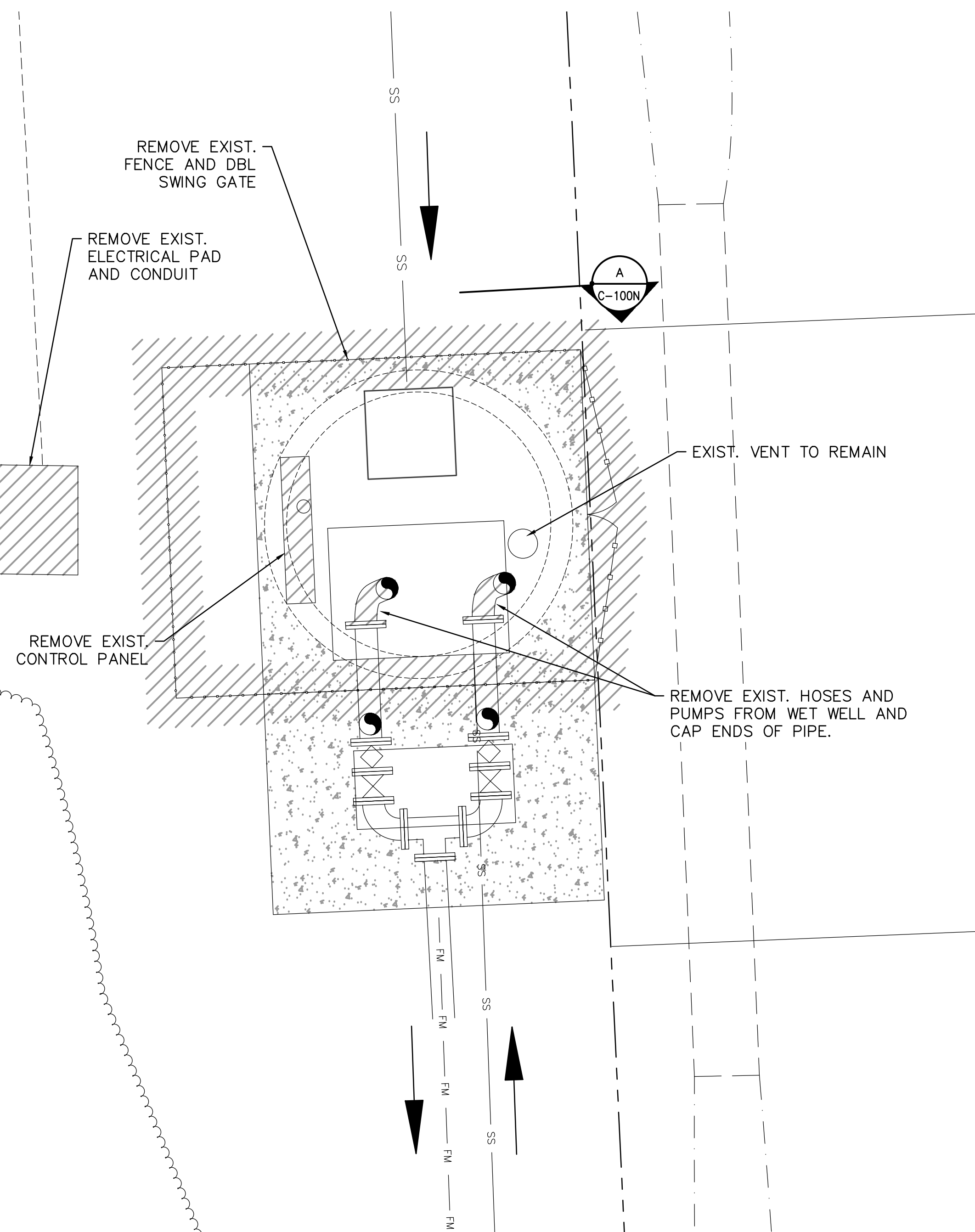

1
C-100N
DEMOLITION PLAN
NTS

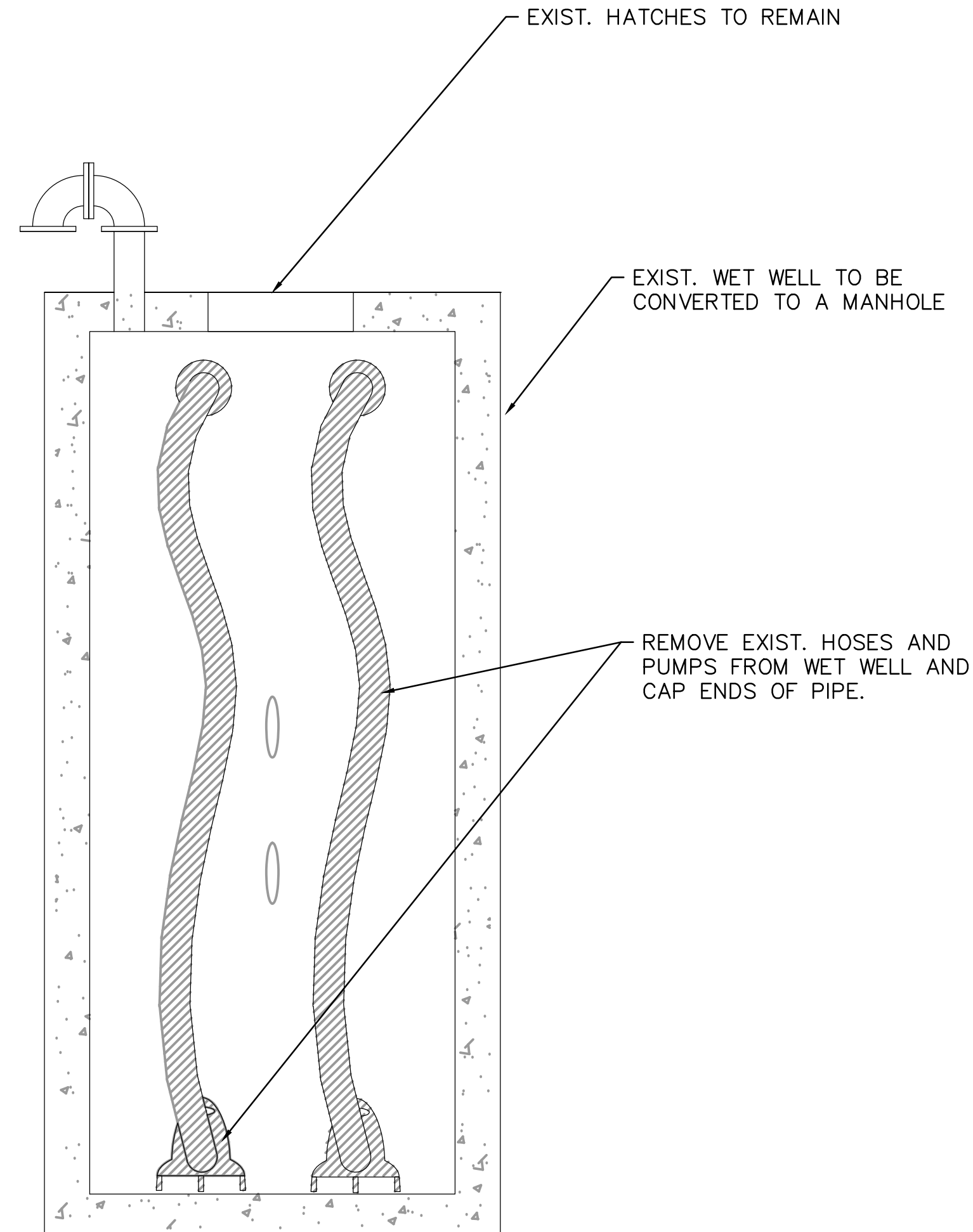

A
C-100N
SECTION
NTS

NOTES:

1. AT OWNER'S DISCRETION, EQUIPMENT REMOVED FROM THE EXISTING STATION SHALL BE SALVAGED AND TURNED OVER TO OWNER.
2. ALL PUMP STATION DEMOLITION AND SITE RESTORATION SHALL BE PERFORMED IN ACCORDANCE WITH SECTIONS 02 41 13 AND 26 05 01 OF THE SPECIFICATIONS.
3. CONTRACTOR SHALL LOCATE ALL EXISTING UTILITIES ON THE SITE.
4. CONTRACTOR SHALL COORDINATE ALL POWER SUPPLY DEMOLITION WITH ENTERGY PRIOR TO INITIATING DEMOLITION WORK.
5. THE CONTRACTOR SHALL COORDINATE TO INSTALL NEW EQUIPMENT AND DISCONNECT EXISTING EQUIPMENT TO MINIMIZE DOWNTIME. BYPASS PUMPING IS REQUIRED WHILE PUMP STATION AND INFLEUENT GRAVITY SEWER ARE NOT IN SERVICE.
6. THE CONTRACTOR SHALL COORDINATE WITH THE OWNER AND ENGINEER, AND SUBMIT A SEQUENCE OF CONSTRUCTION TO MEET THE ABOVE REQUIREMENT. THE OWNER AND ENGINEER RESERVE THE RIGHT TO APPROVE, DISAPPROVE OR REVISE AS DEEMED NECESSARY.
7. ALL EXISTING CONDUIT AND JUNCTION BOXES SHALL BE REMOVED BACK TO THEIR SOURCE ORIGIN. JUNCTION BOXES SHALL BE REMOVED. EXISTING UNDERGROUND SERVICE CONDUIT SHALL BE FILLED WITH CONCRETE AND ABANDONED. SEAL AND PATCH PENETRATION. USE UL LISTED MATERIALS.
8. PATCH AND GROUT WALL PENETRATIONS AND COAT INTERIOR OF EXISTING WET WELL.
9. EXISTING ELECTRICAL SERVICE EQUIPMENT SHALL BE REMOVED IN COORDINATION WITH THE UTILITY COMPANY.
10. ALL WORK SHALL BE DONE IN STRICT ACCORDANCE WITH THE LATEST EDITION OF THE NEC CODE AND LOCAL REQUIREMENTS.

NO.	REVISION	DATE

PROJECT NO.: 77183-00
CAD FILE: C-100N.DWG
ENGR./ARCH.: MKP
DESIGN BY: MKP
DRAWN BY: DMB
CHECKED BY: MKP
DATE: 04/26/2018
DRAWING INTENT IS TO INDICATE GENERAL ARRANGEMENT, DESIGN AND INTENT OF WORK AND IS PARTLY DIAGRAMMATIC. DRAWING SHALL NOT BE SCALED.
© Buchart Horn, Inc.

DEMOLITION PLAN

DRAWING NO.
C-100N

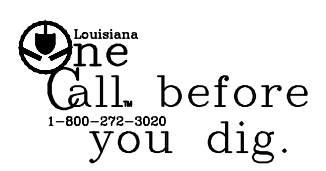

PRIOR TO WORK COMMENCEMENT, THE CONTRACTOR IS RESPONSIBLE FOR FINAL VERIFICATION OF THE LOCATION OF THE UTILITIES SHOWN ON THESE PLANS. THE CONTRACTOR SHALL CALL LOUISIANA ONE CALL (811 OR 800-272-3020) AND CITY PARISH DEPARTMENT OF PUBLIC WORKS TO THE UTILITIES LOCATED PRIOR TO CONSTRUCTION. THE CONTRACTOR IS RESPONSIBLE FOR COORDINATING WITH THE UTILITY COMPANIES FOR ALL AREAS OF CONSTRUCTION.

A:\PROJECTS\77183-00\CAD\000\TitleSheet\C-100.dwg 6/27/2018 12:57:08 PM

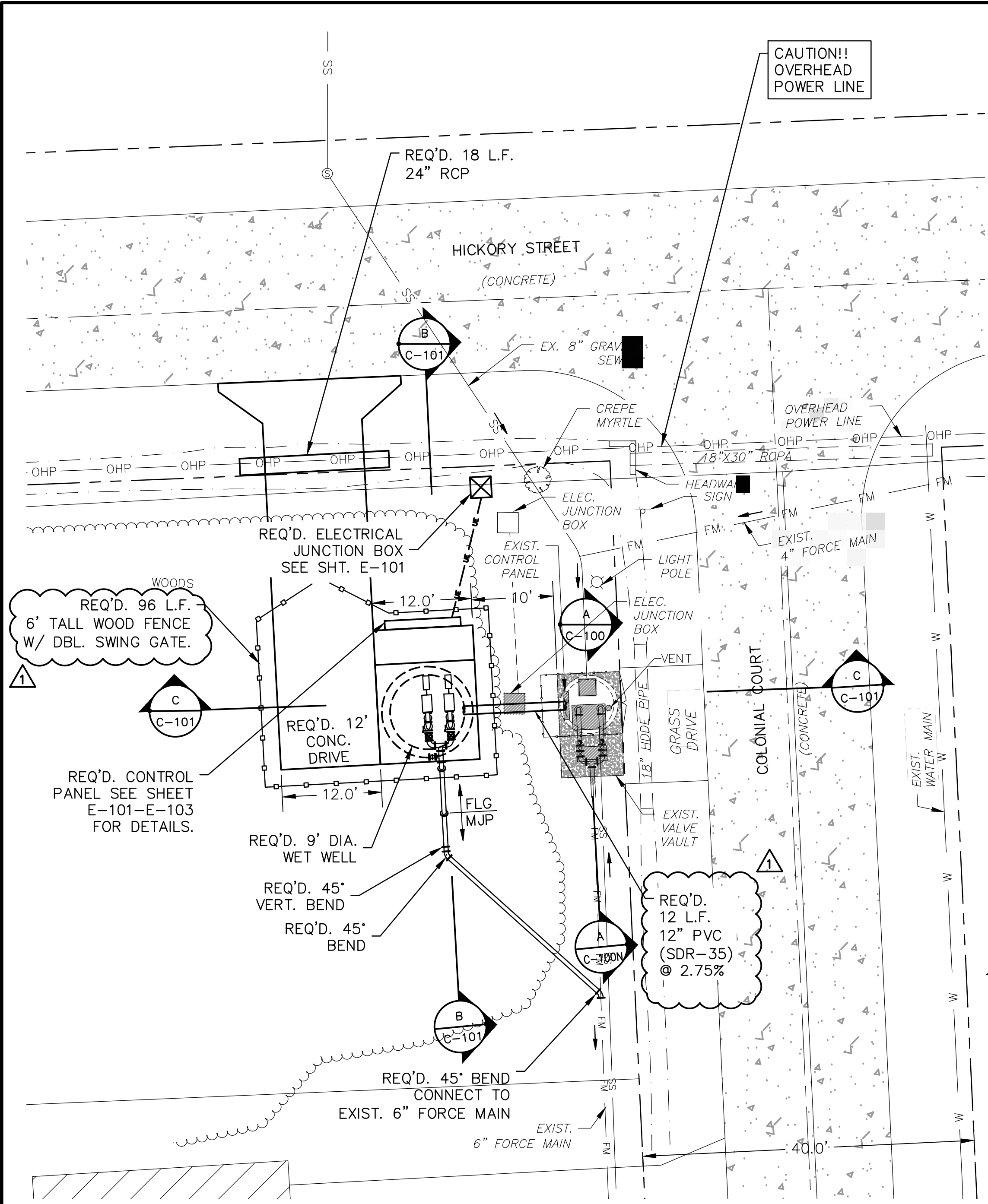

SITE PLAN

GENERAL NOTES:

- UTILITIES SHOWN ARE APPROXIMATE AND HAVE NOT BEEN FIELD VERIFIED. NO SURVEY HAS BEEN CONDUCTED. CONTRACTOR TO EXPOSE AND MEASURE ALL UTILITY DEPTHS AND LOCATIONS PRIOR TO CONSTRUCTION.
- SITE ADDRESS: 436 COLONIAL COURT
- ALL HARDWARE BELOW LID OR INSIDE WET WELL (I.E. NUTS, BOLTS, BRACKETS, RAILS, BRACERS, SUPPORTS, LIFTING CABLES, ETC.) SHALL BE 316 STAINLESS STEEL.
- CONTRACTOR TO SEAL EXISTING WET WELL AND NEW WET WELL WITH SPECTRASHIELD POLYMER LINING SYSTEM OR APPROVED EQUAL. THE FINISHED SYSTEM SHALL PROVIDE 250 MILS MINIMUM COVER. DURING APPLICATION, A WET FILM THICKNESS GAGE SHALL BE USED TO ENSURE A MONOLITHIC COATING AND UNIFORM THICKNESS.
- DESIRED OPERATING POINT IS 713.5 GPM AT 145 FT. TDH. PUMPS, DRIVE SYSTEMS AND MOTORS SHALL BE PROVIDED AS A COMPLETE SYSTEM CAPABLE OF SUPPLYING THE REQUIRED FLOW AT THE DESIRE OPERATING POINT WITH ONE DUTY PUMP AND ONE STAND BY PUMP.
- PARISH WILL CLEAR THE TREES FROM THE SITE FOR THE WORK PRIOR TO ISSUING A NTP FOR THIS WORK.
- UNLESS OTHERWISE INDICATED, ALL 90° ELBOWS SHALL BE LONG RADIUS 90° ELBOWS.

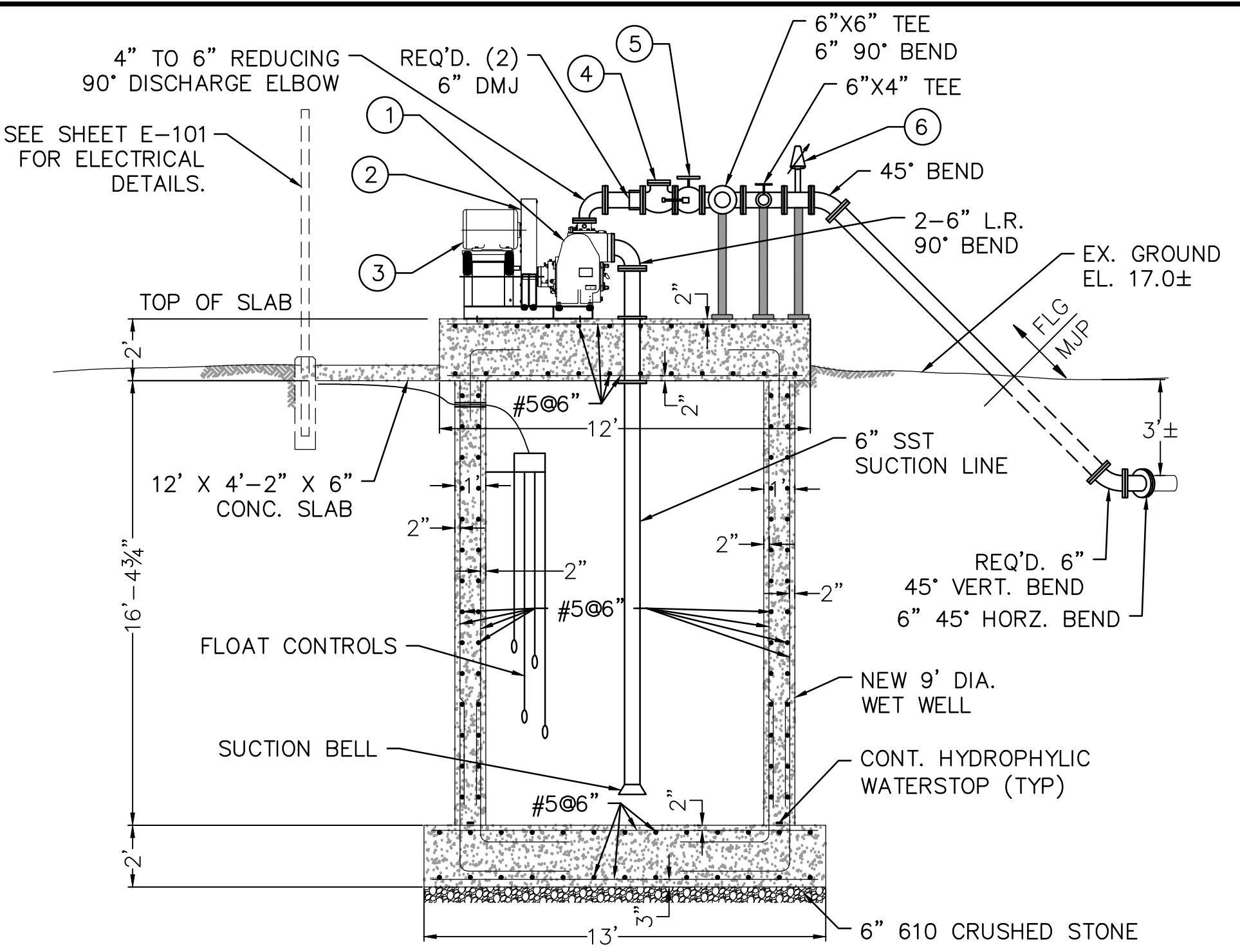

NEW LIFT STATION SECTION

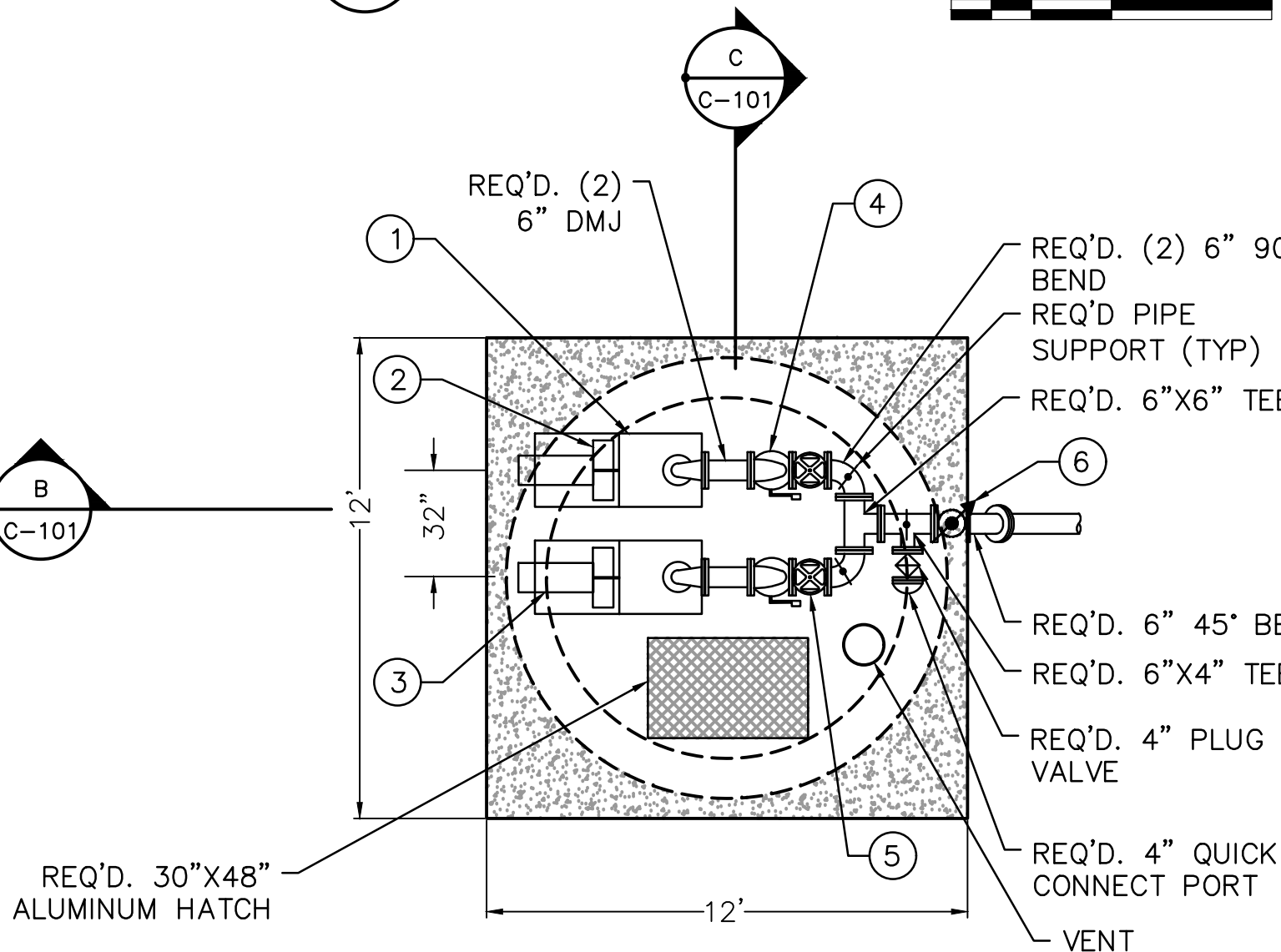

NEW LIFT STATION PLAN

KEY NOTES:

- SELF PRIMING CENTRIFUGAL PUMP (TYP. OF 2)
- V BELT DRIVE SYSTEM (TYP. OF 2)
- 480V, 3 PHASE ELECTRIC MOTOR (TYP. OF 2)
- 6" CHECK VALVE (TYP. OF 2)
- 6" PLUG VALVE (TYP. OF 2)
- 2" COMBINATION AIR VALVE

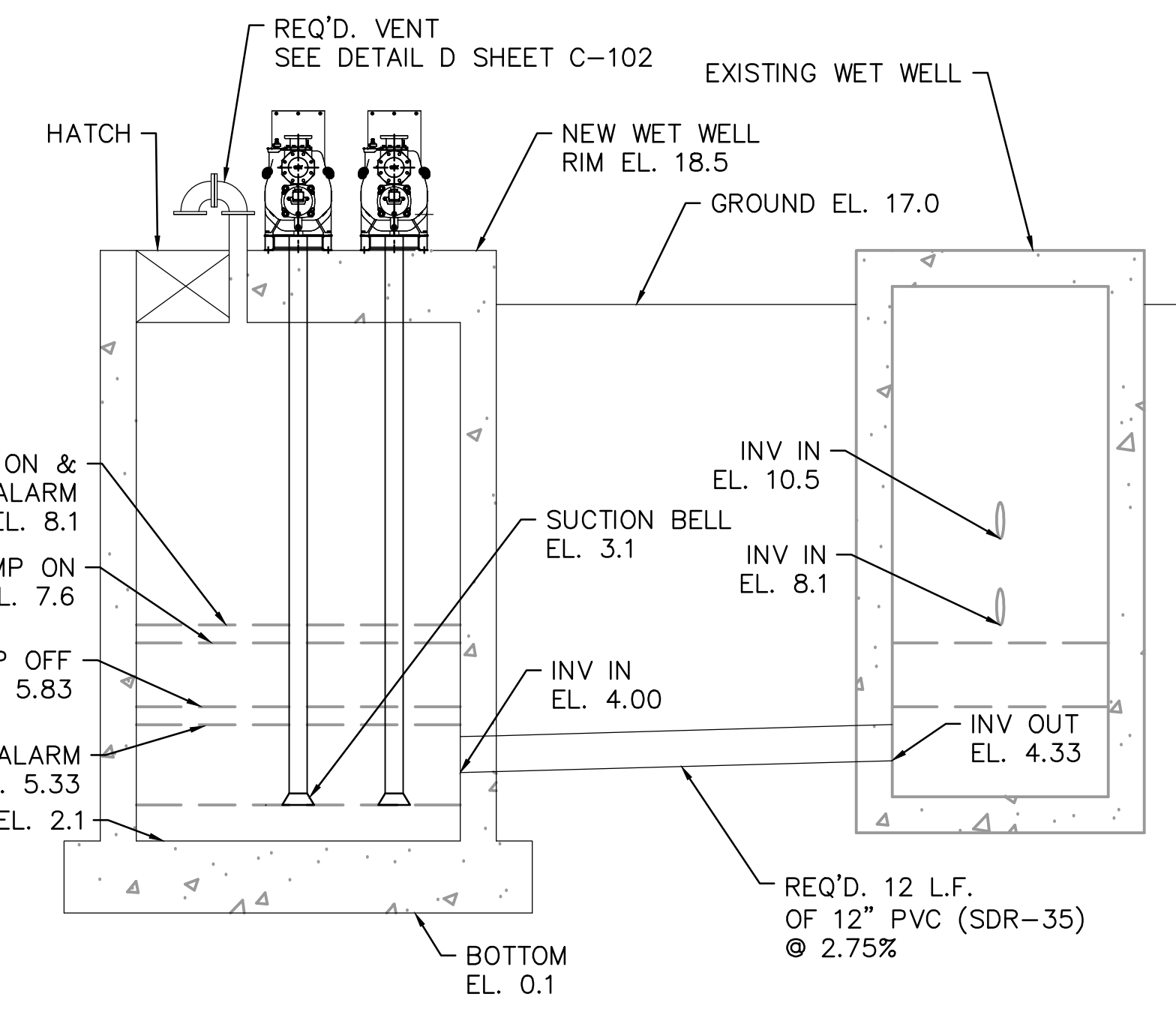

NEW LIFT STATION PROFILE

ABBREVIATIONS

AVE.	AVENUE	L.F.	LINEAR FEET
BLVD.	BOULEVARD	L.R.	LONG RADIUS
CONC.	CONCRETE	LN	LANE
CONT.	CONTINUOUS	MJP	MECHANICAL JOINT PIPE
CT.	COURT	N.	NORTH
DIA.	DIAMETER	OHP	OVERHEAD POWER LINE
DMJ	DISMANTLING JOINT	PVC	POLYVINYLCHLORIDE
DR.	DRIVE	RCP	REINFORCED CONCRETE PIPE
E.	EAST	REQ'D	REQUIRED
EL.	ELEVATION	S.	SOUTH
ELEC.	ELECTRICAL	SHT.	SHEET
EX.	EXISTING	SS	SANITARY SEWER
EXIST.	EXISTING	SST	STAINLESS STEEL
FLG	FLANGE PIPE	ST.	STREET, SAINT
FM	FORCE MAIN	TYP	TYPICAL
HOPE	HIGH DENSITY POLYETHYLENE	VERT.	VERTICAL
HORIZ.	HORIZONTAL	W	WEST, WATER MAIN
INV.	INVERT		

NO.	REVISION	DATE	BY	DMB

PROJECT NO.: 77183-00
CAD FILE: C-101R.DWG
ENGR./ARCH.: MKP
DESIGN BY: MKP
DRAWN BY: DMB
CHECKED BY: MKP
DATE: 04/26/2018

DRAWING INTENT IS TO INDICATE GENERAL ARRANGEMENT, DESIGN AND INTENT OF WORK AND IS PARTLY DIAGRAMMATIC. DRAWING SHALL NOT BE SCALED.
© BUCHART HORN, INC.

NO.	REVISION	BY	DATE

PROJECT NO.:	77183-00
CAD FILE:	C-102R.DWG
ENGR./ARCH.:	MKP
DESIGN BY:	MKP
DRAWN BY:	DMB
CHECKED BY:	MKP
DATE:	04/26/2018
DRAWING INTENT IS TO INDICATE GENERAL ARRANGEMENT, DESIGN AND INTENT OF WORK AND IS PARTLY DIAGRAMMATIC. DRAWING SHALL NOT BE SCALED.	
© BUCHART HORN, INC.	

CONCRETE
SLAB
DETAILS

DRAWING NO.
C-102R

SHEET 4 OF 6

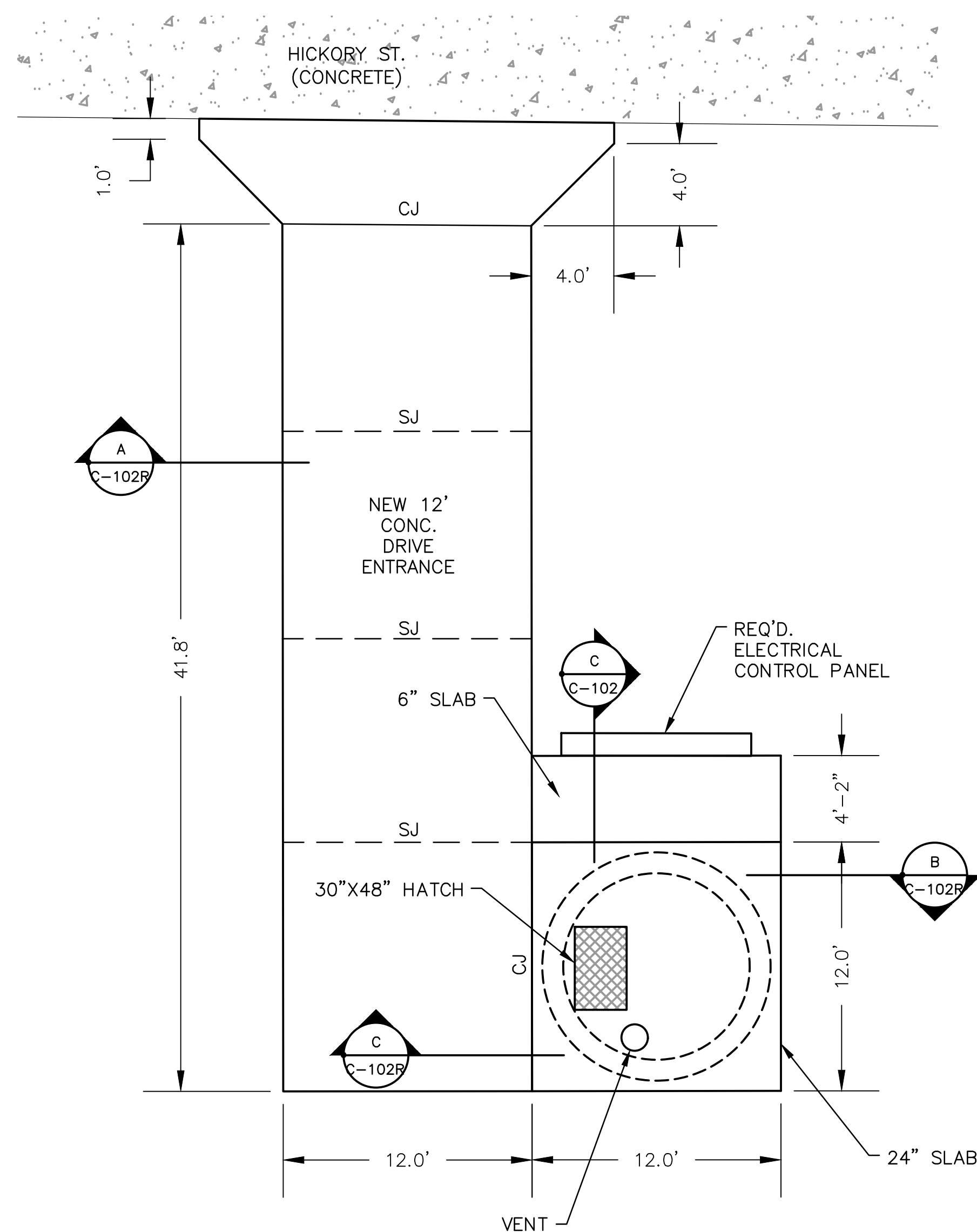

1 CONCRETE SLAB DETAIL
C-102R

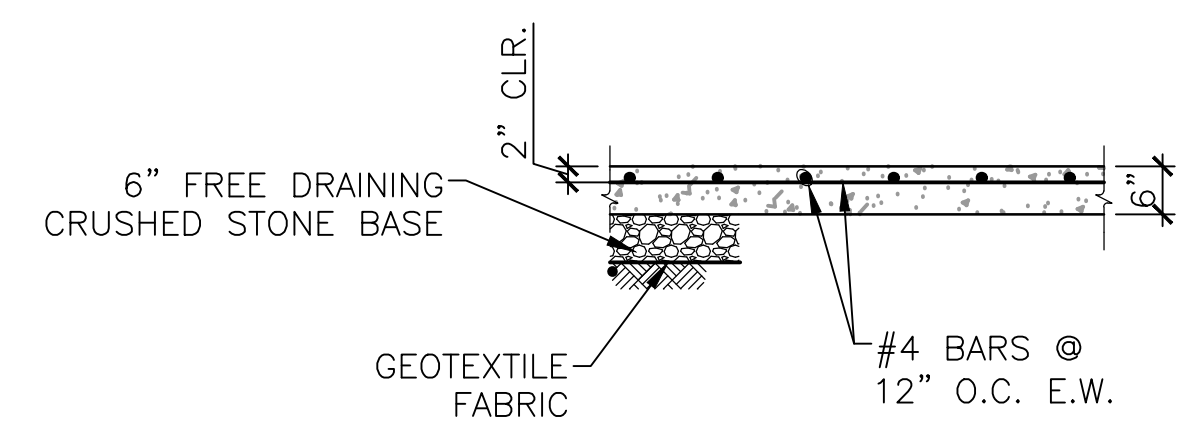

A 6" CONCRETE PAVEMENT DETAIL
C-102R

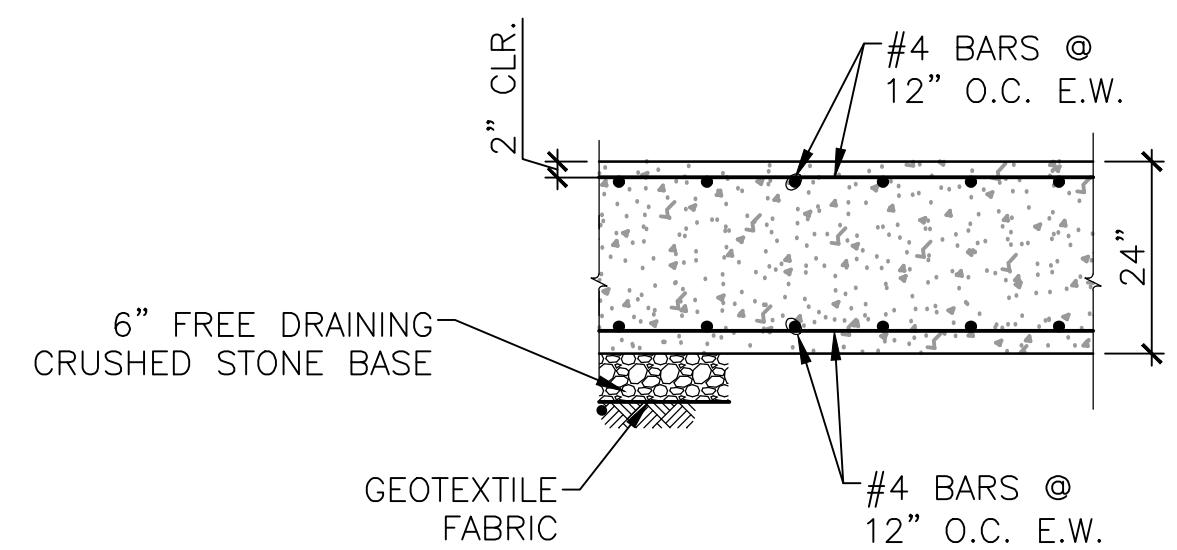

B 24" CONCRETE SLAB DETAIL
C-102R

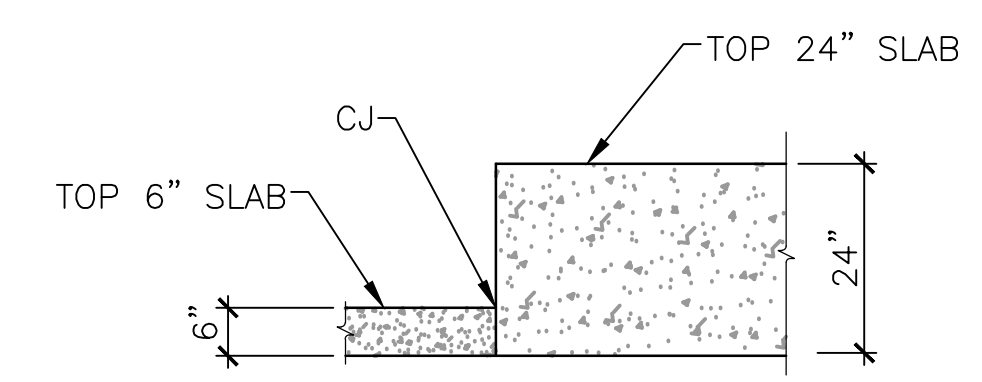

C SECTION C
C-102R

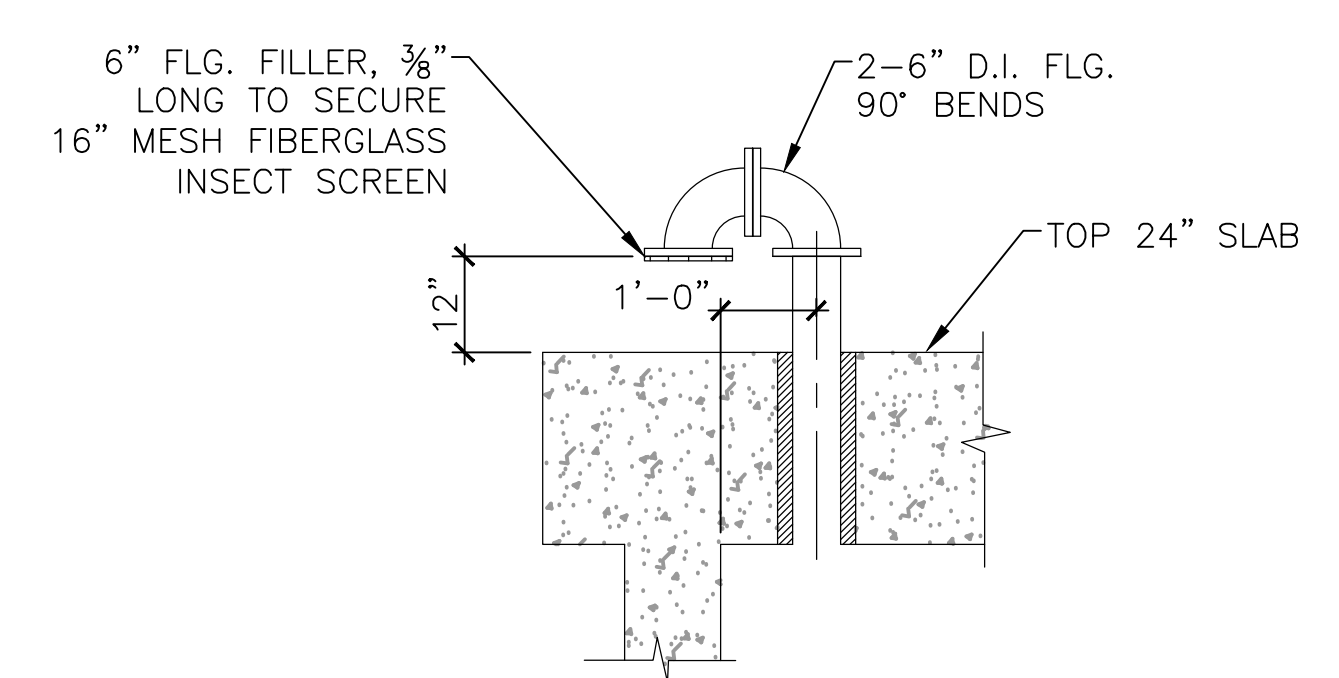

D VENT PIPE DETAIL
C-102R

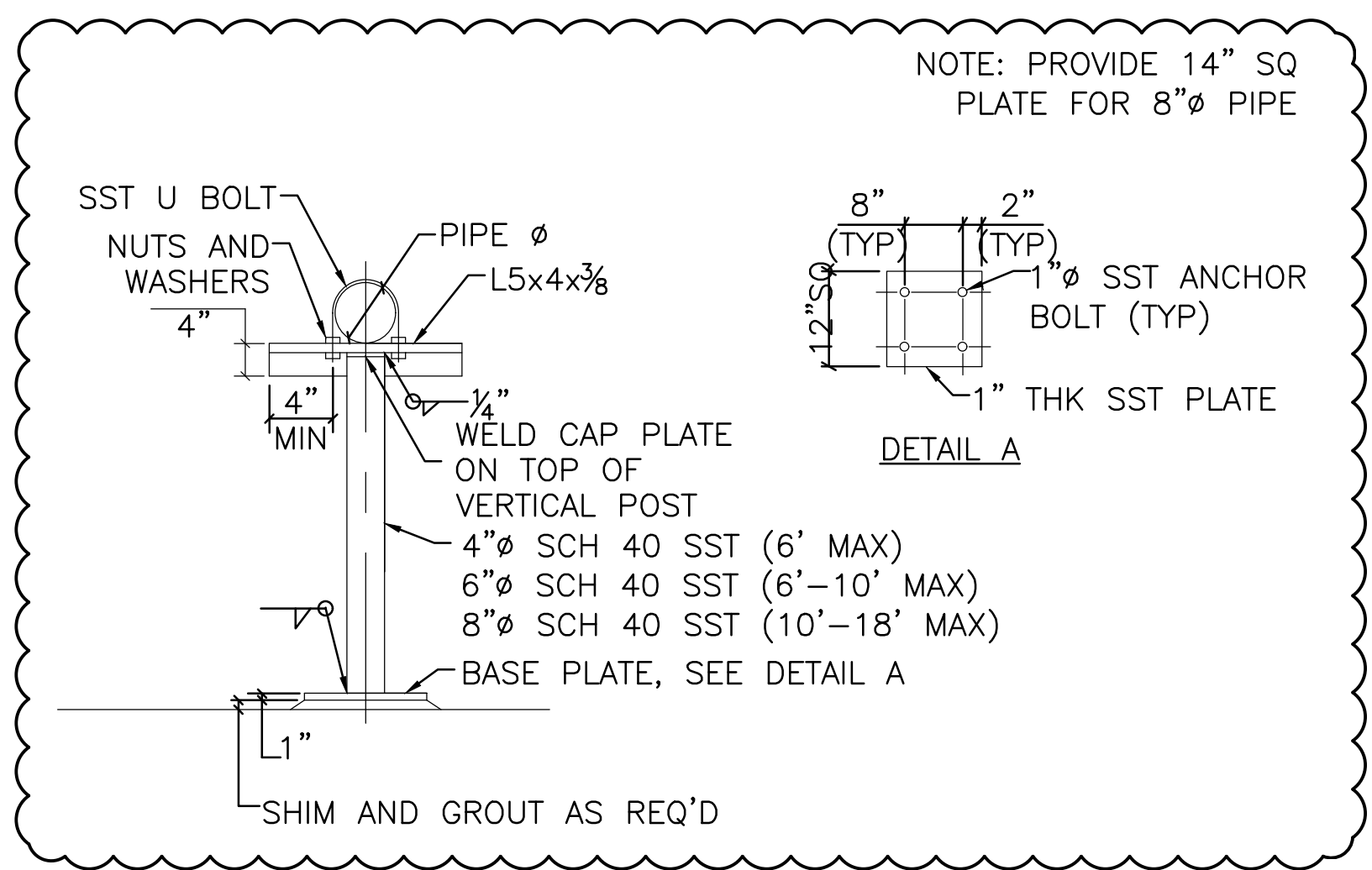

2 PIPE SUPPORT
C-102R

NTS

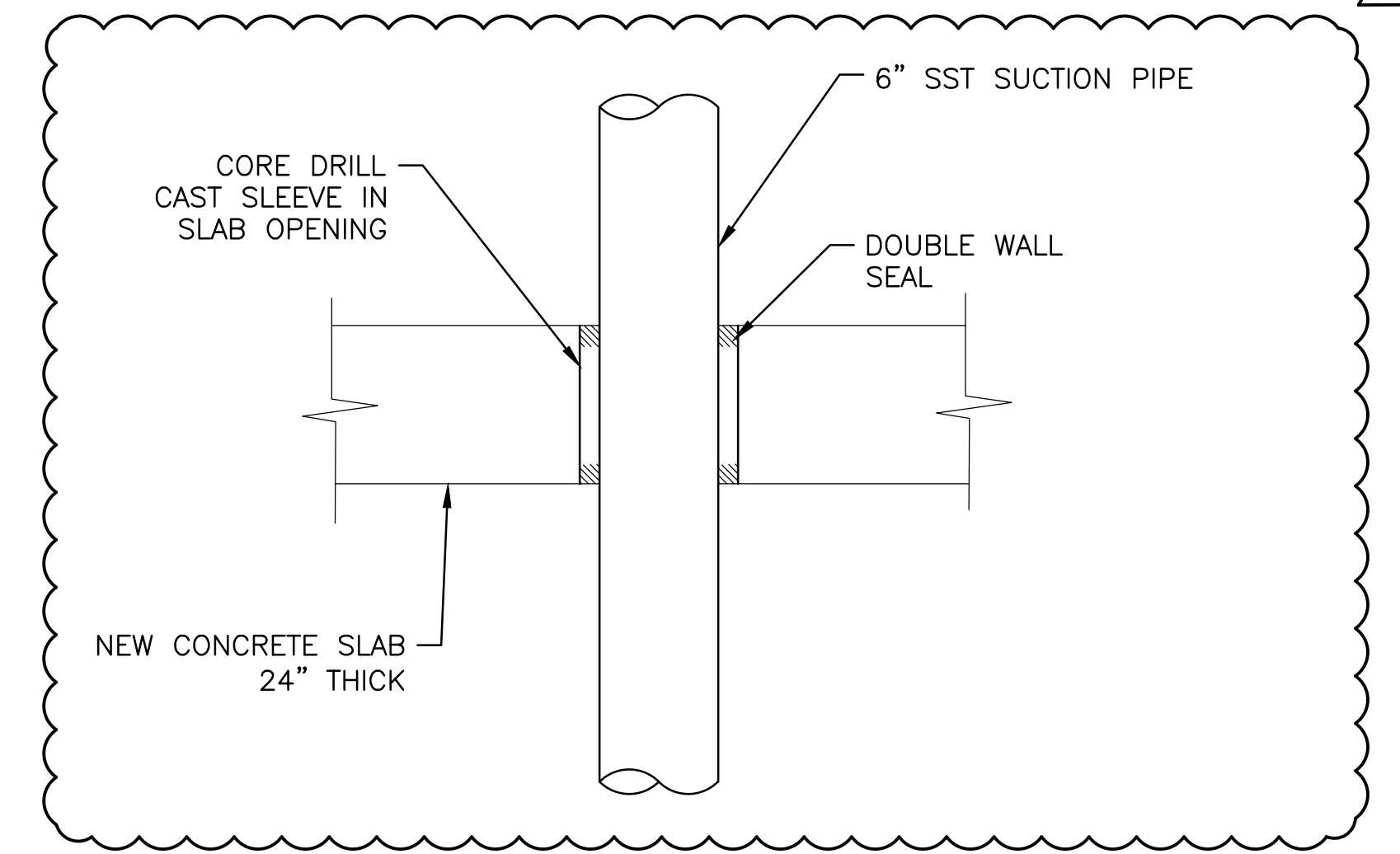

3 ROOF PENETRATION
C-102R

NTS

Call before you dig.

1-800-972-9820

PRIOR TO WORK COMMENCEMENT, THE CONTRACTOR IS RESPONSIBLE FOR FINAL VERIFICATION OF THE LOCATION OF THE UTILITIES SHOWN ON THESE PLANS. THE CONTRACTOR SHALL CALL LOUISIANA ONE CALL (811 OR 800-272-3020) AND CITY PARISH DEPARTMENT OF PUBLIC WORKS TO THE UTILITIES LOCATED PRIOR TO CONSTRUCTION. THE CONTRACTOR IS RESPONSIBLE FOR COORDINATING WITH THE UTILITY COMPANIES FOR ALL AREAS OF CONSTRUCTION.

AL:\PROJ\77183-00\CAD\CON\TAM\Sheet\C-102R.dwg 07/26/2018 2:51:45 PM

Section 10
Project Specifications

SECTION 00 01 10 - TABLE OF CONTENTS - Revised

PROCUREMENT AND CONTRACTING REQUIREMENTS

SPECIFICATIONS

Division 02 -- Existing Conditions

02 41 13 - Site Demolition

Division 03 -- Concrete

03 30 00 - Cast-in-Place Concrete

03 60 00 - Grout

Division 09 -- Finishes

09 90 00 – Painting

09 96 00 – High Performance Coatings (new – Addendum 1)

Division 25 -- Integrated Automation

25 02 00 - Control Panel

Division 26 -- Electrical

26 05 01 - Electrical Demolition

26 05 19 - Low-Voltage Electrical Power Conductors and Cables

26 05 26 - Grounding and Bonding for Electrical Systems

26 05 29 - Hangers and Supports for Electrical Systems

26 05 34 - Conduit

26 05 37 - Boxes

26 05 53 - Identification for Electrical Systems

26 21 00 - Low-Voltage Electrical Service Entrance

26 28 16.16 - Enclosed Switches

26 36 00 - Transfer Switches

26 56 00 - Exterior Lighting

Division 31 -- Earthwork

31 20 00 - Earthwork

31 23 17 - Trenching, Backfilling and Compacting

Division 33 -- Utilities

33 01 30.13 - Sewer and Manhole Testing

33 31 13 - Sanitary Sewer Pipe (revised - Addendum 1)

33 32 00 - Sewage Pump Station

END OF SECTION 00 01 10

SECTION 09 96 00 - HIGH PERFORMANCE COATINGS

PART 1 GENERAL

1.1 DESCRIPTION:

- A. A corrosion resistant liner that restores the surface profile and eliminates water infiltration and exfiltration.

1.2 REFERENCES

- A. American Society for Testing and Materials (ASTM):
 1. D7234 - Adhesion
 2. D412 - Tensile Strength (PSI)
 3. D412 - Elongation (%)
 4. D624 - Tear Strength (PLI)
 5. D2240 - Hardness
 6. D522 - Flexibility (1/8" mandrel)
 7. D4060 - Taber Abrasion (mg loss)

1.3 SUBMITTALS

- A. All materials and procedures required to establish compliance with the specifications shall be submitted upon request to the owner/engineer for review/approval. Submittals shall include at least the following:
 1. Technical Data Sheet on each product used.
 2. Safety Data Sheet (SDS) for each product used.
 3. Manufacturer's Certification of Applicator.
 4. Certified Applicator Minimum Qualifications.
 5. Descriptive literature, bulletins and or catalogs of materials.
 6. Work procedures including flow diversion plan, method of repair, etc.
 7. Material and method for repair of leaks or cracks in the structure.
 8. Applicator and Manufacturer warranty forms

1.4 QUALITY ASSURANCE

- A. The manufacturer of the total lining system for wastewater structures shall be a company that specializes in the design and manufacture of corrosion protection materials / systems for wastewater structures.
- B. The applicator (company performing the installation) shall be completely trained in leak repair, surface preparation and application of the lining system.
- C. The materials/products shall be suitable for installation in a wastewater environment without any deterioration of the liner.
- D. The applicator shall be trained and provide a letter of certification from the manufacturer for the handling, mixing, application, and inspection of the liner system as described herein.
- E. To ensure total unit responsibility, all materials and installation thereof shall be furnished and coordinated by manufacturer/certified applicator.

1.5 WARRANTY

- A. Applicator and Manufacturer must warrant the liner system installation against failure for a period of 10 years from the installation date. Applicator shall correct failures any time prior to 10 years after the installation date. Failure will be deemed to have occurred if the protective liner fails to: (a) prevent the

internal corrosion of the structure or (b) prevent groundwater infiltration. Failure does not include damage resulting from mechanical force or the presence of chemical substances not customarily present or used in Wastewater Structures, defects in the workmanship or devices of others upon which the Wastewater Structure functions or act of God. The liner must be installed in accordance with Manufacturer's instructions by Applicators certified by Manufacturer. Executed 10-year Applicator and Manufacturer warranties are to be provided upon completion of work.

PART 2 PRODUCTS

2.1 MATERIALS AND EQUIPMENT

A. The materials to be utilized in the lining of wastewater structures shall be designed and manufactured to withstand the severe effects a wastewater environment. The manufacturer of the corrosion protection products shall have at least 10 years of experience in the production of the lining products utilized, and the products shall have satisfactory installation record.

B. Equipment for installation of lining materials shall be of high quality and as recommended by the manufacturer.

C. The lining system to be utilized for wastewater structures shall be a multi-layer 'stress skin panel' liner system as described below:

1. Liner

Installation

Moisture barrier
 Surfacers
 Final corrosion barrier

Liner

Modified Polymer (Silicone modified polyurea)
 Polyurethane/Polymeric blend foam
 Modified polymer (Silicone modified Polyurea)

2. The Modified polymer (silicone modified polyurea) shall be sprayable, solvent free, two-component polymeric, moisture/chemical barrier specifically developed for the corrosive wastewater environment.

3. The Polyurethane Rigid Structure Foam, shall be low viscosity two-component, containing flame retardants.

4. Total thickness of multi-layer liner system shall be a minimum of 500 mils.

D. The product shall be SPECTRASHIELD, manufactured by CCI Spectrum, Inc, or equal.

PART 3 EXECUTION

3.1 INITIAL INSPECTION

A. Applicator shall take appropriate action to comply with all local, state, and federal regulations including those set forth by OSHA, EPA, the Owner and any other applicable authorities.

B. Prior to conducting any work, an initial inspection of the structure shall be performed to determine need for protection against hazardous gases or oxygen depleted atmosphere and the need for flow control or flow diversion.

C. If required, submit a plan for flow control or bypass to the owner/engineer for approval prior to conducting the work.

D. New Portland cement structures shall have endured a minimum of 28 days since manufacture prior to commencing installation of the liner system.

3.2 SURFACE PREPARATION

- A. The surface preparation program will include checking the atmosphere for hydrogen sulfide, methane, low oxygen, or other gases, approved flow control equipment, and surface preparation equipment.
- B. Surface preparation for standard manhole structures shall be in accordance with the manufacturer's recommendations, and may include high pressure water cleaning and shall provide a surface compatible for installation of the liner system.
- C. Surface preparation and methods for other structures shall be in accordance with the manufacturer's recommendations, and may include high pressure water cleaning, hydro blasting, abrasive blasting, grinding, or detergent water cleaning, and shall be suited to provide a surface compatible for installation of the liner system.
- D. The surface preparation method shall produce a cleaned, abraded and sound surface with no evidence of laitance, loose concrete, loose brick, loose mortar, contaminants or debris, and shall display a surface profile suitable for application of the liner system in accordance with the manufacturer's recommendations.
- E. After completion of surface preparation, inspecting for:
 - 1. Leaks
 - 2. Cracks
 - 3. Holes
 - 4. Exposed Rebar
 - 5. Ring and Cover Condition
 - 6. Invert Condition
 - 7. Inlet and Outlet Pipe Condition
- F. After the defects in the structure are identified, repair all leaks and severe cracks with Spectra-Grout, or other methods approved by the manufacturer.
- G. Upon completion of leak and crack repair, the surface shall be primed in accordance with the manufacturer's recommendations.

3.3 MATERIAL INSTALLATION

- A. Application procedures shall conform to recommendations of the manufacturer, including materials handling, mixing, environmental controls during application, safety and spray equipment.
- B. Spray equipment shall be specifically designed to accurately ratio and apply the liner system.
- C. Application of multi-component liner system shall be in strict accordance with manufacturer's recommendation. Final installation minimum total thickness shall be 500 mils. A permanent identification and date of work performed shall be affixed to the structure in a readily visible location.
- D. A final written report shall be provided to the owner/engineer detailing the location, date of work and description of the work.

3.4 FINAL INSPECTION

- A. Final liner system shall be completely free of pinholes or voids. Liner thickness shall be the minimum value as described herein.

- B. Visual inspection may be made by the Owner/Engineer. Any deficiencies in the finished liner system shall be marked and repaired according to the procedures set forth by the manufacturer.

END OF SECTION 09 96 00

SECTION 33 31 13 - SANITARY SEWER PIPE - Revised

PART 1 GENERAL

1.1 DESCRIPTION

- A. The Work of this section includes, but is not limited to:
 - 1. Sanitary sewer gravity pipelines
 - 2. Sanitary sewer pressure pipelines
- B. Related Work specified elsewhere:
 - 1. Section 31 23 17 - Trenching, Backfilling, and Compacting
 - 2. Section 33 01 30.13 - Sewer Testing

1.2 QUALITY ASSURANCE

- A. Reference Standards:
 - 1. American National Standards Institute (ANSI):
 - a. ANSI/AWWA C104/A21.4 - Cement Mortar Lining for Ductile-Iron Pipe and Fittings for Water
 - b. ANSI/AWWA C110/A21.10 - Ductile-Iron and Gray-Iron Fittings, 3" through 48", for Water and Other Liquids
 - c. ANSI/AWWA C111/A21.11 - Rubber Gasket Joints for Ductile-Iron Pressure Pipe and Fittings
 - d. ANSI/AWWA C153/A21.53 - Ductile-Iron Compact Fittings For Water Service
 - e. ANSI/AWWA C151/A21.51 - Ductile-Iron Pipe Centrifugally Cast
 - 2. American Society for Testing and Materials (ASTM):
 - a. ASTM C76 Reinforced Concrete Culvert, Storm Drain, and Sewer Pipe
 - b. ASTM C443 Joints for Circular Concrete Sewer and Culvert Pipe Using Rubber Gaskets
- B. Materials contaminated with gasoline, lubricating oil, liquid or gaseous fuel, aromatic compounds, paint solvent, paint thinner, or acid solder will be rejected.

1.3 SUBMITTALS

- A. Submit each manufacturer's certification attesting that the pipe, pipe fittings, joints, joint gaskets and lubricants meet or exceed specification requirements.

1.4 PRODUCT DELIVERY, STORAGE AND HANDLING

- A. Do not place materials on private property.
- B. During loading, transporting and unloading, exercise care to prevent damage to materials.
- C. Do not drop pipe or fittings.
- D. Avoid shock or damage at all times.
- E. Take measures to prevent damage to the exterior surface or internal lining of the pipe.
- F. Do not stack pipe higher than recommended by the pipe manufacturer.
- G. Store gaskets for mechanical and push-on joints in a cool, dry location out of direct sunlight and not in contact with petroleum products.

PART 2 PRODUCTS

2.1 CONCRETE SEWER PIPE

- A. Reinforced Gravity Sewer Pipe and Fittings: ASTM C76, Reinforced Concrete Culvert, Storm Drain and Sewer Pipe Class III, Wall A.
- B. Joints: Tongue and groove, or bell and spigot.
- C. Gaskets: Solid circular cross-section O-ring, ASTM C443. Joints for circular concrete sewer and culvert pipe, using rubber gaskets.
- D. Provide in the internal design pressure rating, and for the live and dead loads as indicated on the Contract Drawings.

2.2 DUCTILE-IRON PIPE

- A. Pipe, ANSI/AWWA C151/A21.51; standard cement mortar lining, ANSI/AWWA C104/A21.4, outside coated.
 - 1. Pipe - 3" to 12": Pressure Class - 350 psi
- B. Ductile Iron Fittings:
 - 1. ANSI/AWWA C110/A21.10 or C153/A21.53; fittings psi pressure rating to match required pipe rating above.
 - 2. Fitting to be cement mortar lined and outside coated as for ductile iron pipe.
- C. Joints (ANSI/AWWA C111/A21.11): Where not specifically indicated on the Contract Drawings, joints may be either mechanical joint or push-on joint.
- D. Flanged Joints: ANSI/AWWA C110/A21.10
- E. Rubber Gaskets, Lubricants, Glands, Bolts and Nuts: ANSI/AWWA C111/A21.11.

2.3 STAINLESS STEEL PIPE

- A. Pipe: Welded; ASTM A312, TP 304L; and ANSI B36.19, Schedules 5S, 10S and 40S, as indicated on the Drawings.
- B. Fittings:
 - 1. ASTM A403, WP 304L.
- C. Joints: Welded, flanged, or threaded as indicated on the Drawings. All flanges shall be stainless steel. All bolts shall be stainless steel.

2.4 DISMANTLING JOINTS

- A. Flange Spool: AWWA Class D flange compatible with ANSI Class 125 and 150 bolt circles. For 3 inches through 12 inches, pipe is Schedule 40 ASTM A53. For 14 inches through 24 inches pipe materials are ASTM A36.
- B. Body: ASTM A536 ductile (nodular) iron meeting or exceeding Grade 65-45-12 with ANSI Class 125 and 150 bolt circles.
- C. Gaskets: ASTM D 2000.
- D. Restraining Bolts: 7/8 -9 roll thread, ductile (nodular) iron, meeting or exceeding ASTM A536.
- E. Restraining Lugs: Ductile (nodular) iron, meeting or exceeding ASTM A536.

- F. Lug Locators: Polyurethane, a thermal plastic.
- G. T-bolts and Nuts: High strength low alloy steel T-head bolt. National coarse rolled thread and heavy hex nut. Steel meets AWWA C111 composition specifications.
- H. Coatings: Fusion bonded epoxy, NSF 61 certified.
- I. Manufacturer: Romac Industries, Inc., Model DJ405, or equal.

2.5 THRUST RESTRAINT

- A. Provide pressure pipeline with restrained joints or concrete thrust blocks at all bends, tees, and changes in direction.
- B. Submit design calculations showing determination of restrained lengths and submit joint restraint details. Method of joint restraint shall utilize devices specifically designed for the application for which manufacturer's data is available for the application. Submit manufacturer's literature for approval.

2.6 FLEXIBLE COUPLINGS

- A. Elastomeric plastic sleeve resistant to chemicals and normal sewer gases leakproof and rootproof; positive seal against infiltration and exfiltration; stainless steel clamp bands.
- B. Manufacturer: Fernco, Davison Michigan, or equal.

PART 3 EXECUTION

3.1 PREPARATION

- A. Perform trench excavation to the line and grade indicated on the Contract Drawings and as specified in Section 31 23 17 - Trenching, Backfilling and Compacting.
- B. Unless otherwise indicated on the Contract Drawings, provide for a minimum cover of 4 feet above the top of piping laid in trenches.
- C. Provide pipe bedding as specified in Section 31 23 17 - Trenching, Backfilling and Compacting for each type of pipe used.
- D. Place aggregate in a manner to avoid segregation, and compact to the maximum practical density so that the pipe can be laid to the required tolerances.

3.2 LAYING PIPE IN TRENCHES

- A. Give ample notice to the Engineer in advance of pipe laying operations.
- B. Use laser alignment instruments.
- C. Lower pipe into trench using handling equipment designed for the purpose to assure safety of personnel and to avoid damage to pipe. Do not drop pipe.
- D. Lay pipe proceeding upgrade with the bell or groove pointing upstream.
- E. Lay pipe to a true uniform line with the barrel of the pipe resting solidly in pipe bedding material throughout its length.
- F. Excavate recesses in pipe bedding material to accommodate joints, fittings and appurtenances.
- G. Do not subject pipe to a blow or shock to achieve solid bearing or grade.

- H. Lay each section of pipe in such a manner as to form a close concentric joint with the adjoining section and to avoid offsets in the flow line.
- I. Clean and inspect each section of pipe before joining.
- J. Assemble to provide tight, flexible joints that permit movement caused by expansion, contraction, and ground movement.
- K. Use lubricant recommended by the pipe or fitting manufacturer for making joints.
- L. If unusual joining resistance is encountered or if the pipe cannot be fully inserted into the bell, disassemble joint, inspect for damage, reclean joint components, and reassemble joint.
- M. Assemble joints in accordance with recommendations of the manufacturer.
- N. Push-on Joints:
 1. Clean the inside of the bell and the outside of the spigot.
 2. Insert rubber gasket into the bell recess.
 3. Apply a thin film of gasket lubricant to either the inside of the gasket or the spigot end of the pipe, or both.
 4. Insert the spigot end of the pipe into the socket using care to keep the joint from contacting the ground.
 5. Complete the joint by forcing the plain end to the bottom of the socket.
 6. Mark pipe that is not furnished with a depth mark before assembly to assure that the spigot is fully inserted.
- O. Mechanical Joints:
 1. Wash the socket and plain end.
 2. Apply a thin film of soapy water.
 3. Slip the gland and gasket over the plain end of the pipe.
 4. Apply soapy water to gasket.
 5. Insert the plain end of the pipe into the socket and seat the gasket evenly in the socket.
 6. Slide the gland into position, insert bolts, and finger-tighten nuts.
 7. Bring bolts to uniform tightness; tighten bolts 180 degrees apart alternately.
- P. Reinforced Concrete Joints:
 1. Wipe clean end of the pipe and inside of rubber gasket.
 2. Equalize gasket circumferential tension.
 3. Apply joint lubricant.
 4. Insert pipe into coupling, bell or groove and force into place to the bottom of the socket.
 5. After joint assembly, check rubber ring location with a suitable gage.
- Q. Flanged Joints:
 1. Tighten flange bolts so that the gasket is uniformly compressed and sealed; do not distort flanges; do not exceed manufacturer's recommended maximum torque.
 2. Leave flange bolts with ends projecting 1/8 inch to 1/4 inch beyond the face of the nut after tightening.
- R. Disassemble and remake improperly assembled joints using a new gasket.
- S. Grade Check:
 1. Check each pipe installed as to line and grade in place.
 2. Correct deviation from grade immediately.

- 3. A deviation from the designed grade as shown on the Contract Drawings, or deflection of pipe joints, will be cause for rejection.
- T. Place sufficient backfill on each section of pipe, as it is laid, to hold firmly in place.
- U. Clean interior of the pipe as work progresses; where cleaning after laying is difficult because of small pipe size, use a suitable swab or drag in the pipe and pull forward past each joint immediately after the jointing has been completed.
- V. Keep trenches and excavations free of water during construction.
- W. When the work is not in progress, and at the end of each workday, securely plug open ends of pipe and fittings to prevent trench water, earth, or other substances from entering the pipes or fittings.
- X. When it is necessary to deflect pressure sewer mains from a straight alignment horizontally or vertically, do not exceed the following limits:
 - 1. Ductile-Iron Pipe: Per AWWA C600.

3.3 BACKFILLING TRENCHES

- A. Backfill pipeline trenches only after examination of the pipe laying by the Engineer.
- B. Backfill trenches as specified in Section 31 23 17 - Trenching, Backfilling and Compacting.

END OF SECTION 33 31 13